

TK⁺/TPK⁺/TPK⁺ HIGH TORQUE – new right-angle precision as flange version



The successor to our versatile hypoid gearhead with TP⁺ compatible output flange and hollow shaft, with optional planetary stage (TPK⁺).

Quick size selection

TK⁺ (ex. i = 5)
For applications in cyclic operation (ED ≤ 60%)

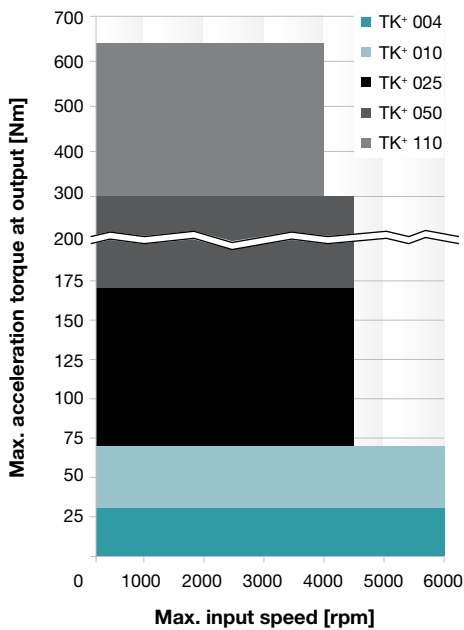

TPK⁺ MF (ex. i = 25)
For applications in cyclic operation (ED ≤ 60%)

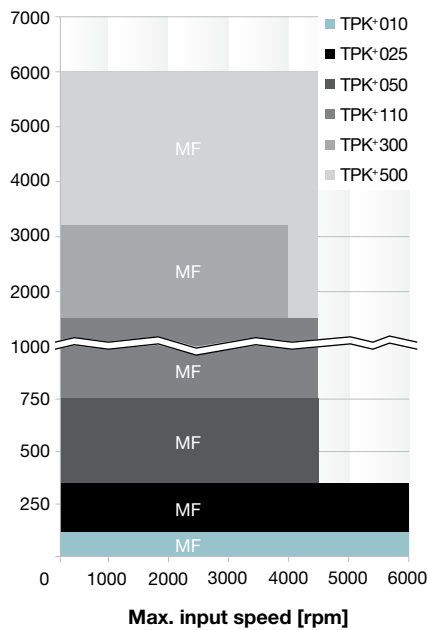

TPK⁺ HIGH TORQUE MA (ex. i = 88)
For applications in cyclic operation (ED ≤ 60%)

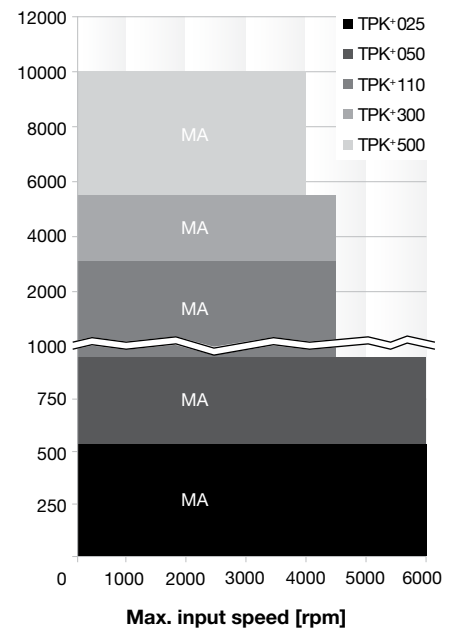

Versions and Applications

TK+

- High power density
- Cyclic applications
- Reverse operation
- Highly dynamic applications
- Hollow shaft version

TPK+ MF version

- High positioning accuracy
- Cyclic applications
- Highly dynamic applications

TPK+ HIGH TORQUE MA version

- Maximum power density
- Maximum positioning accuracy

Comparison

Features		TK+ from page 152	TPK+ MF version from page 162	TPK+ HIGH TORQUE MA version from page 188
Ratios ^{c)}		3 - 100	12 - 10000	66 - 5500
Torsional backlash [arcmin] ^{c)}	Standard	≤ 4	≤ 4	≤ 1,3
	Reduced	-	≤ 2	-
Output type				
Smooth output shaft, rear side		•	•	•
Keywayed output shaft, rear side		•	•	•
Output flange			•	•
Hollow shaft interface, rear side Connected via shrink disc		•	•	•
Flanged hollow shaft		•		
Closed cover, rear side		•	•	•
System output with pinion			•	•
Input type				
Motor mounted version		•	•	•
Type				
ATEX ^{a)}		•		
Food-grade lubrication ^{a) b)}		•	•	•
Corrosion resistant ^{a) b)}		•	•	•
Accessories				
Coupling		•	•	•
Rack		•	•	•
Pinion		•	•	•
Shrink disc		•	•	•
torqXis sensor flange		•	•	•
Flange shaft		•	•	•
Intermediate plate for cooling connection		•	•	•
Spindle system		•		

^{a)} Power reduction; technical data available upon request

^{b)} Please contact WITTENSTEIN alpha

^{c)} In relation to reference sizes



MF

MA

TK+ 004 MF 1/2-stage

		1-stage					2-stage											
Ratio ^{a)}	<i>i</i>	3	4	5	7	10	12	16	20	25	28	35	40	50	70	100		
Max. acceleration torque (max. 1000 cycles per hour)	T_{2B}	Nm	30	30	30	25	20	30	30	30	30	30	30	30	25	20		
		in.lb	266	266	266	221	177	266	266	266	266	266	266	266	266	221	177	
Nominal output torque (with n_m)	T_{2N}	Nm	22	22	22	20	15	22	22	22	22	22	22	22	20	15		
		in.lb	195	195	195	177	133	195	195	195	195	195	195	195	195	177	133	
Emergency stop torque (permitted 1000 times during the service life of the gearhead)	T_{2Not}	Nm	40	50	50	45	40	50	50	50	50	50	50	50	45	40		
		in.lb	354	443	443	398	354	443	443	443	443	443	443	443	443	398	354	
Nominal input speed (with T_{2N} and 20 °C ambient temperature) ^{b), c)}	n_{1N}	rpm	2200	2400	2700	2700	2700	4400	4400	4400	4400	4400	4400	4800	5500	5500		
Max. continuous speed (with 20% T_{2N} and 20 °C ambient temperature)	n_{1Ncym}	rpm	2700	3100	3600	3100	3100	5000	5000	5000	5000	5000	5000	5000	5500	5500		
Max. input speed	n_{1Max}	rpm	6000	6000	6000	6000	6000	6000	6000	6000	6000	6000	6000	6000	6000	6000		
Mean no load running torque (with $n_1=3000$ rpm and 20 °C gearhead temperature) ^{d)}	$T_{01/2}$	Nm	1.4	1.3	1.2	1.4	1.3	0.2	0.2	0.2	0.2	0.2	0.2	0.1	0.1	0.1		
		in.lb	12.4	11.5	10.6	12.4	11.5	1.8	1.8	1.8	1.8	1.8	1.8	0.9	0.9	0.9		
Max. torsional backlash	j_t	arcmin	≤ 5															
Torsional rigidity	C_{t21}	Nm/arcmin	2.6	2.8	3.0	2.6	2.3	2.8	2.8	2.8	2.8	2.8	2.8	2.8	3.0	2.6	2.3	
		in.lb/arcmin	23	25	26	23	20	25	25	25	25	25	25	25	26	23	20	
Max. axial force ^{e)}	F_{2AMax}	N	2400															
		lb _f	540															
Max. radial force ^{e)}	F_{2RMax}	N	2700															
		lb _f	608															
Max. tilting moment	M_{2KMMax}	Nm	251															
		in.lb	2220															
Efficiency at full load	η	%	96					94										
Service life (For calculation, see the Chapter "Information")	L_h	h	> 20000															
Weight incl. standard adapter plate	<i>m</i>	kg	2.9					3.2										
		lb _m	6.4					7.1										
Operating noise (with $n_1=3000$ rpm no load)	L_{PA}	dB(A)	≤ 64															
Max. permitted housing temperature		°C	+90															
		F	194															
Ambient temperature		°C	0 to +40															
		F	32 to 104															
Lubrication			Lubricated for life															
Paint			Blue RAL 5002															
Direction of rotation			Motor and gearhead opposite directions															
Protection class			IP 65															
Moment of inertia (relates to the drive) Clamping hub diameter [mm]	B	11	J_t	kgcm ²	-	-	-	-	-	0.09	0.09	0.08	0.07	0.06	0.06	0.06	0.06	
				10 ⁻³ in.lb.in ²	-	-	-	-	-	0.08	0.08	0.07	0.07	0.06	0.06	0.05	0.05	0.05
	C	14	J_t	kgcm ²	0.57	0.46	0.41	0.37	0.35	0.21	0.20	0.19	0.19	0.18	0.18	0.17	0.17	0.17
				10 ⁻³ in.lb.in ²	0.50	0.41	0.36	0.33	0.31	0.18	0.18	0.17	0.16	0.16	0.16	0.15	0.15	0.15
E	19	J_t	kgcm ²	0.92	0.82	0.76	0.72	0.70	-	-	-	-	-	-	-	-		
			10 ⁻³ in.lb.in ²	0.81	0.72	0.68	0.64	0.62	-	-	-	-	-	-	-	-		

Please contact us for information on the best configuration for S1 conditions of use (continuous operation).

- ^{a)} Other ratios available on request
- ^{b)} Higher speeds are possible if the nominal torque is reduced
- ^{c)} For higher ambient temperatures, please reduce input speed
- ^{d)} Idling torques decrease during operation
- ^{e)} Refers to center of the output shaft or flange

All technical data for front output side applies.
Technical data for rearward output versions, see page 386.

View A

1-stage:

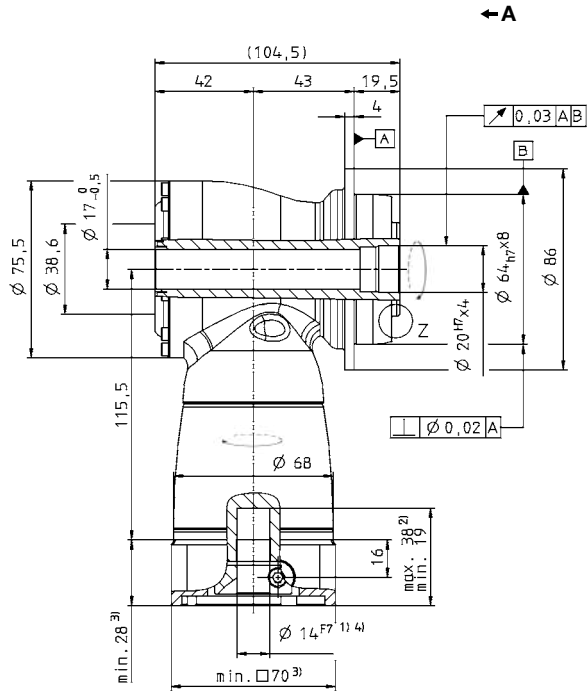
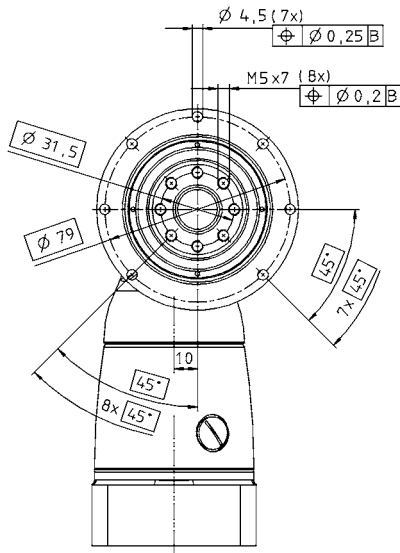

2-stage:

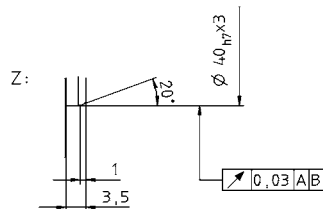
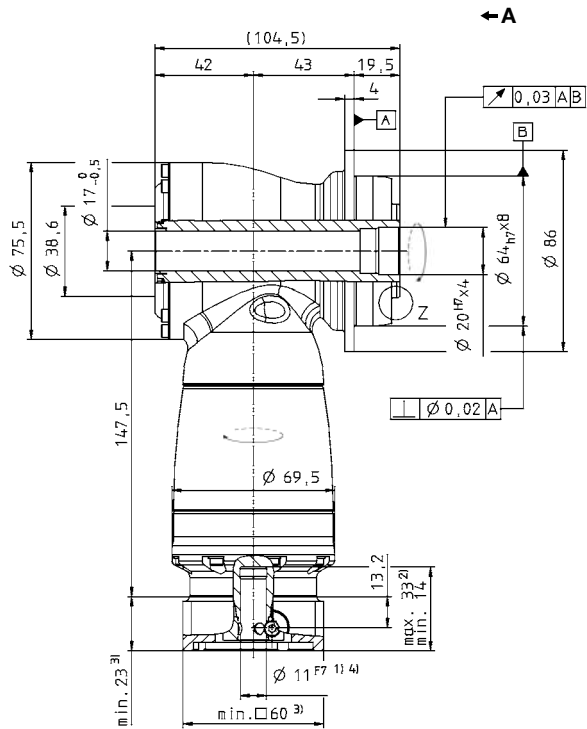
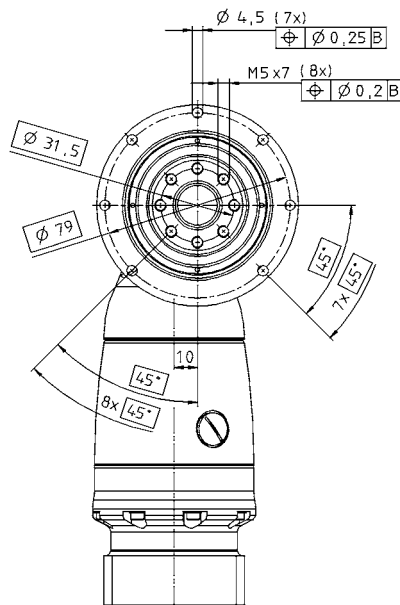

See technical data sheet for available clamping hub diameters (mass moment of inertia). Dimensions available on request.

Non-tolerated dimensions ± 1 mm

- 1) Check motor shaft fit.
- 2) Min./Max. permissible motor shaft length. Longer motor shafts are adaptable, please contact us.
- 3) The dimensions depend on the motor.
- 4) Smaller motor shaft diameter is compensated by a bushing with a minimum thickness of 1 mm.

CAD data is available under www.wittenstein-alpha.com

Motor mounting according to operating manual

TK+ 010 MF 1/2-stage

		1-stage					2-stage													
Ratio ^{a)}	<i>i</i>	3	4	5	7	10	12	16	20	25	28	35	40	50	70	100				
Max. acceleration torque (max. 1000 cycles per hour)	T_{2B}	Nm	70	70	70	60	50	70	70	70	70	70	70	70	60	50				
		in.lb	620	620	620	531	443	620	620	620	620	620	620	620	620	531	443			
Nominal output torque (with n_m)	T_{2N}	Nm	50	50	50	45	40	50	50	50	50	50	50	50	45	40				
		in.lb	443	443	443	398	354	443	443	443	443	443	443	443	443	398	354			
Emergency stop torque (permitted 1000 times during the service life of the gearhead)	T_{2Not}	Nm	95	115	115	110	100	115	115	115	115	115	115	115	110	100				
		in.lb	841	1018	1018	974	885	1018	1018	1018	1018	1018	1018	1018	1018	974	885			
Nominal input speed (with T_{2N} and 20 °C ambient temperature) ^{b), c)}	n_{1N}	rpm	2100	2200	2500	2500	2500	3500	3500	3500	3500	3500	3500	3500	3800	4500				
Max. continuous speed (with 20% T_{2N} and 20 °C ambient temperature)	n_{1Ncym}	rpm	2700	3100	3600	3100	3100	4500	4500	4500	4500	4500	4500	4500	4500	4500				
Max. input speed	n_{1Max}	rpm	6000	6000	6000	6000	6000	6000	6000	6000	6000	6000	6000	6000	6000	6000				
Mean no load running torque (with $n_1=3000$ rpm and 20 °C gearhead temperature) ^{d)}	$T_{01/2}$	Nm	2.4	2.0	1.8	2.4	2.2	0.4	0.4	0.3	0.3	0.3	0.3	0.1	0.1	0.1				
		in.lb	21	18	16	21	19	3.5	3.5	2.7	2.7	2.7	2.7	0.9	0.9	0.9				
Max. torsional backlash	j_t	arcmin	≤ 4																	
Torsional rigidity	C_{t21}	Nm/arcmin	6.0	7.0	8.0	8.0	8.0	7.0	7.0	7.0	7.0	7.0	7.0	7.0	8.0	8.0	8.0			
		in.lb/arcmin	53	62	71	71	71	62	62	62	62	62	62	62	71	71	71			
Max. axial force ^{e)}	F_{2AMax}	N	3400																	
		lb _f	765																	
Max. radial force ^{e)}	F_{2RMax}	N	4000																	
		lb _f	900																	
Max. tilting moment	M_{2KMax}	Nm	437																	
		in.lb	3867																	
Efficiency at full load	η	%	96					94												
Service life (For calculation, see the Chapter "Information")	L_h	h	> 20000																	
Weight incl. standard adapter plate	<i>m</i>	kg	5.3					6.1												
		lb _m	11.7					13.5												
Operating noise (with $n_1=3000$ rpm no load)	L_{PA}	dB(A)	≤ 66																	
Max. permitted housing temperature		°C	+90																	
		F	194																	
Ambient temperature		°C	0 to +40																	
		F	32 to 104																	
Lubrication			Lubricated for life																	
Paint			Blue RAL 5002																	
Direction of rotation			Motor and gearhead opposite directions																	
Protection class			IP 65																	
Moment of inertia (relates to the drive) Clamping hub diameter [mm]	C	14	J_t	kgcm ²	-	-	-	-	-	0.31	0.28	0.24	0.23	0.21	0.20	0.19	0.18	0.18	0.18	
				10 ⁻³ in.lb.in ²	-	-	-	-	-	0.27	0.25	0.21	0.21	0.18	0.18	0.17	0.16	0.16	0.16	
	E	19	J_t	kgcm ²	1.81	1.39	1.18	1.02	0.93	0.75	0.72	0.68	0.68	0.63	0.63	0.63	0.63	0.63	0.63	0.63
				10 ⁻³ in.lb.in ²	1.60	1.23	1.05	0.90	0.82	0.64	0.64	0.61	0.60	0.59	0.55	0.55	0.56	0.56	0.55	0.55
H	28	J_t	kgcm ²	3.22	2.80	2.60	2.43	2.34	-	-	-	-	-	-	-	-	-	-	-	
			10 ⁻³ in.lb.in ²	2.85	2.48	2.30	2.15	2.07	-	-	-	-	-	-	-	-	-	-	-	

Please contact us for information on the best configuration for S1 conditions of use (continuous operation).

- ^{a)} Other ratios available on request
- ^{b)} Higher speeds are possible if the nominal torque is reduced
- ^{c)} For higher ambient temperatures, please reduce input speed
- ^{d)} Idling torques decrease during operation
- ^{e)} Refers to center of the output shaft or flange

All technical data for front output side applies.
Technical data for rearward output versions, see page 386.

View A

1-stage:

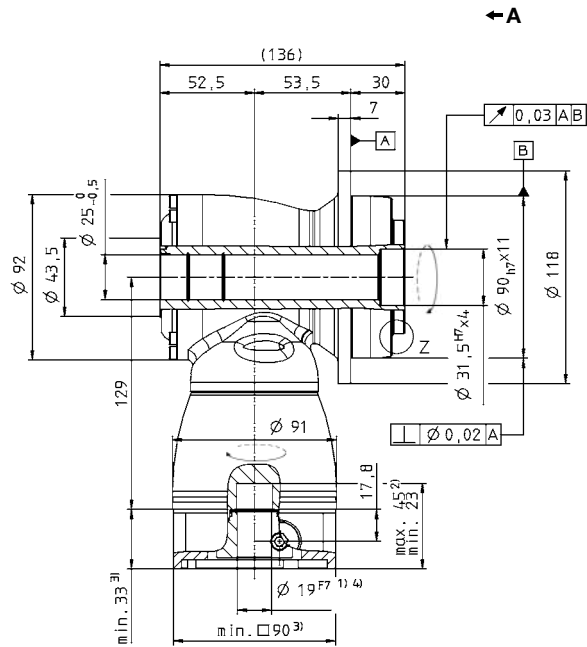
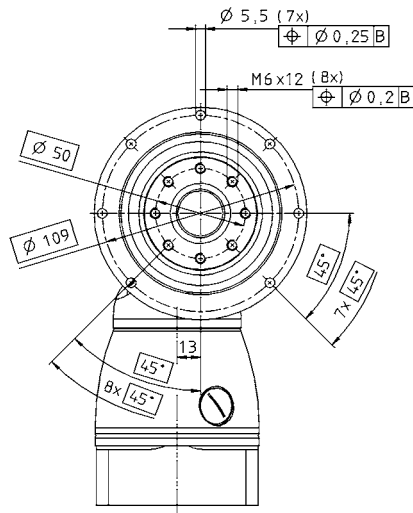

2-stage:

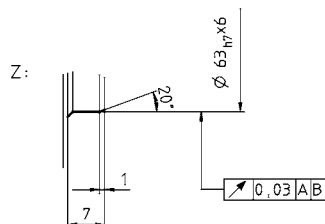
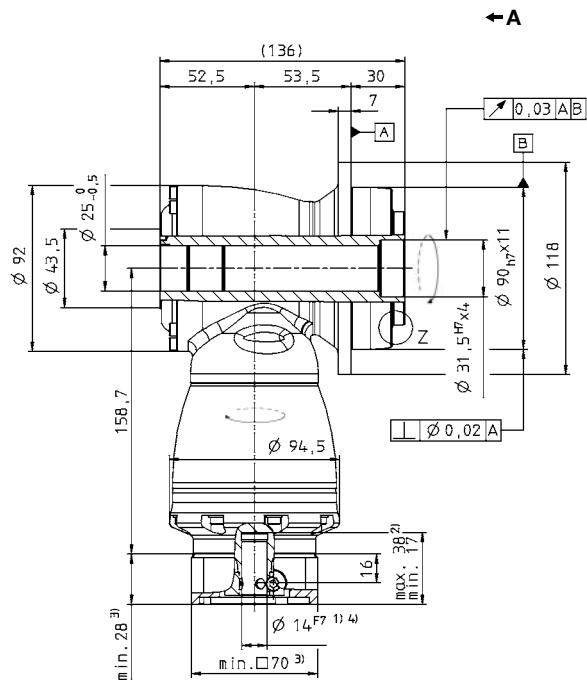
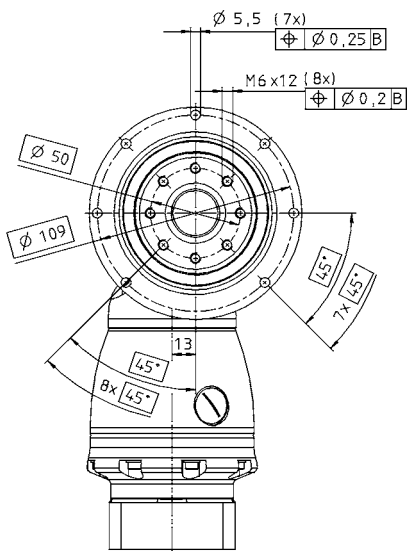

See technical data sheet for available clamping hub diameters (mass moment of inertia). Dimensions available on request.

Non-tolerated dimensions ±1 mm

- 1) Check motor shaft fit.
- 2) Min./Max. permissible motor shaft length. Longer motor shafts are adaptable, please contact us.
- 3) The dimensions depend on the motor.
- 4) Smaller motor shaft diameter is compensated by a bushing with a minimum thickness of 1 mm.

CAD data is available under www.wittenstein-alpha.com

Motor mounting according to operating manual

TK+ 025 MF 1/2-stage

		1-stage					2-stage													
Ratio ^{a)}	<i>i</i>	3	4	5	7	10	12	16	20	25	28	35	40	50	70	100				
Max. acceleration torque (max. 1000 cycles per hour)	T_{2B}	Nm	170	170	170	145	125	170	170	170	170	170	170	170	170	145	125			
		in.lb	1505	1505	1505	1283	1106	1505	1505	1505	1505	1505	1505	1505	1505	1283	1106			
Nominal output torque (with n_m)	T_{2N}	Nm	100	100	100	90	80	100	100	100	100	100	100	100	100	90	80			
		in.lb	885	885	885	797	708	885	885	885	885	885	885	885	885	797	708			
Emergency stop torque (permitted 1000 times during the service life of the gearhead)	T_{2Not}	Nm	220	260	260	255	250	260	260	260	260	260	260	260	260	255	250			
		in.lb	1947	2301	2301	2257	2213	2301	2301	2301	2301	2301	2301	2301	2301	2257	2213			
Nominal input speed (with T_{2N} and 20 °C ambient temperature) ^{b), c)}	n_{1N}	rpm	2000	2100	2400	2200	2200	3100	3100	3100	3100	3100	3100	3100	3500	4200	4200			
Max. continuous speed (with 20% T_{2N} and 20 °C ambient temperature)	n_{1Ncym}	rpm	2700	3000	3400	3000	3000	4000	4000	4000	4000	4000	4000	4000	4000	4200	4200			
Max. input speed	n_{1Max}	rpm	4500	4500	4500	4500	4500	4500	4500	4500	4500	4500	4500	4500	4500	4500	4500			
Mean no load running torque (with $n_1=3000$ rpm and 20 °C gearhead temperature) ^{d)}	$T_{0/2}$	Nm	4.6	3.6	2.8	4.2	3.4	0.7	0.7	0.6	0.5	0.5	0.4	0.2	0.2	0.2	0.2			
		in.lb	41	32	25	37	30	6.2	6.2	5.3	4.4	4.4	3.5	1.8	1.8	1.8	1.8			
Max. torsional backlash	j_t	arcmin	≤ 4																	
Torsional rigidity	C_{t21}	Nm/arcmin	12	13	16	16	16	13	13	13	13	13	13	13	16	16	16			
		in.lb/arcmin	106	115	142	142	142	115	115	115	115	115	115	115	142	142	142			
Max. axial force ^{e)}	F_{2AMax}	N	5700																	
		lb _f	1283																	
Max. radial force ^{e)}	F_{2RMax}	N	6300																	
		lb _f	1418																	
Max. tilting moment	M_{2KMax}	Nm	833																	
		in.lb	7370																	
Efficiency at full load	η	%	96					94												
Service life (For calculation, see the Chapter "Information")	L_h	h	> 20000																	
Weight incl. standard adapter plate	<i>m</i>	kg	8.9					10.6												
		lb _m	20					23												
Operating noise (with $n_1=3000$ rpm no load)	L_{PA}	dB(A)	≤ 66																	
Max. permitted housing temperature		°C	+90																	
		F	194																	
Ambient temperature		°C	0 to +40																	
		F	32 to 104																	
Lubrication			Lubricated for life																	
Paint			Blue RAL 5002																	
Direction of rotation			Motor and gearhead opposite directions																	
Protection class			IP 65																	
Moment of inertia (relates to the drive) Clamping hub diameter [mm]	E	19	J_t	kgcm ²	-	-	-	-	-	1.08	1.01	0.88	0.85	0.76	0.75	0.70	0.69	0.69	0.68	
				10 ⁻³ in.lb.in ²	-	-	-	-	-	0.96	0.89	0.78	0.75	0.67	0.66	0.62	0.66	0.61	0.60	
	G	24	J_t	kgcm ²	-	-	-	-	-	2.65	2.57	2.44	2.42	2.32	2.31	2.26	2.25	2.25	2.25	2.25
				10 ⁻³ in.lb.in ²	-	-	-	-	-	2.34	2.28	2.16	2.14	2.06	2.05	2.00	2.00	1.99	1.99	
	H	28	J_t	kgcm ²	5.50	4.30	3.60	3.10	2.90	-	-	-	-	-	-	-	-	-	-	-
				10 ⁻³ in.lb.in ²	4.83	3.77	3.22	2.77	2.54	-	-	-	-	-	-	-	-	-	-	-
	K	38	J_t	kgcm ²	12.7	11.5	10.9	10.4	10.1	-	-	-	-	-	-	-	-	-	-	-
				10 ⁻³ in.lb.in ²	11.2	10.2	9.63	9.19	8.95	-	-	-	-	-	-	-	-	-	-	-

Please contact us for information on the best configuration for S1 conditions of use (continuous operation).

- ^{a)} Other ratios available on request
- ^{b)} Higher speeds are possible if the nominal torque is reduced
- ^{c)} For higher ambient temperatures, please reduce input speed
- ^{d)} Idling torques decrease during operation
- ^{e)} Refers to center of the output shaft or flange

All technical data for front output side applies.
Technical data for rearward output versions, see page 386.

View A

1-stage:

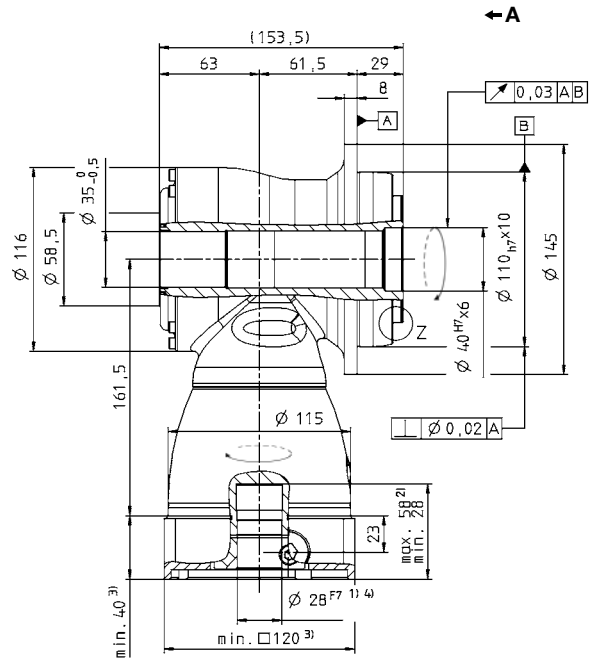
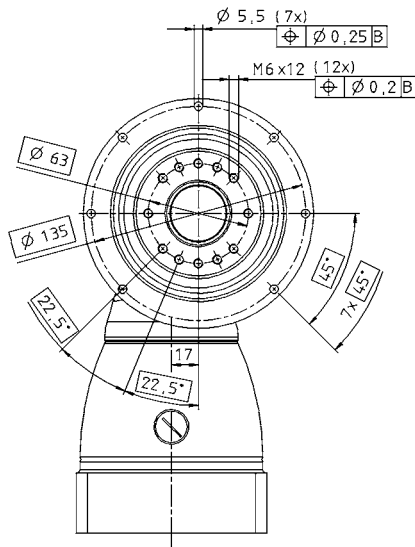

2-stage:

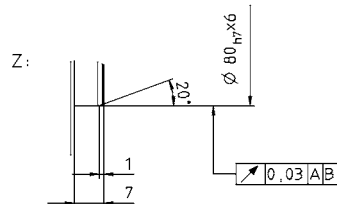
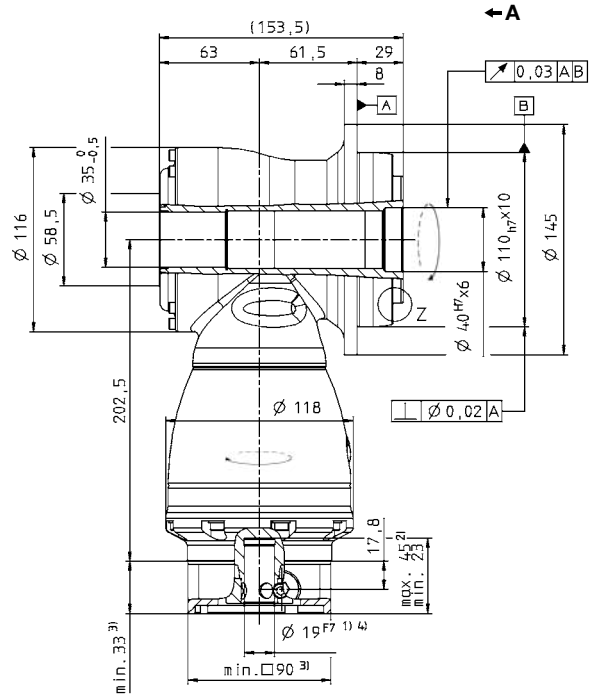
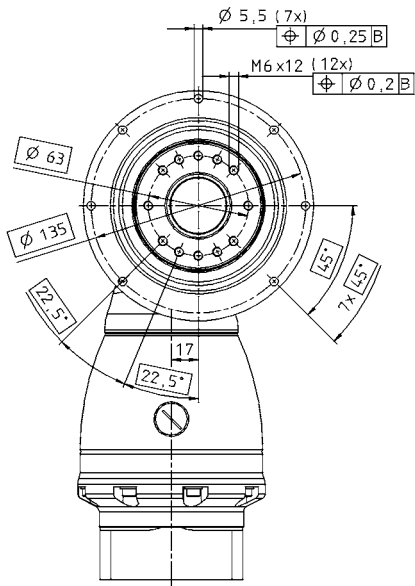

See technical data sheet for available clamping hub diameters (mass moment of inertia). Dimensions available on request.

Non-tolerated dimensions ± 1 mm

- 1) Check motor shaft fit.
- 2) Min./Max. permissible motor shaft length. Longer motor shafts are adaptable, please contact us.
- 3) The dimensions depend on the motor.
- 4) Smaller motor shaft diameter is compensated by a bushing with a minimum thickness of 1 mm.

CAD data is available under www.wittenstein-alpha.com

Motor mounting according to operating manual

TK+ 050 MF 1/2-stage

		1-stage					2-stage												
Ratio ^{a)}	<i>i</i>	3	4	5	7	10	12	16	20	25	28	35	40	50	70	100			
Max. acceleration torque (max. 1000 cycles per hour)	T_{2B}	Nm	300	300	300	250	210	300	300	300	300	300	300	300	300	250	210		
		in.lb	2655	2655	2655	2213	1859	2655	2655	2655	2655	2655	2655	2655	2655	2213	1859		
Nominal output torque (with n_m)	T_{2N}	Nm	190	190	190	175	160	190	190	190	190	190	190	190	190	175	160		
		in.lb	1682	1682	1682	1549	1416	1682	1682	1682	1682	1682	1682	1682	1682	1549	1416		
Emergency stop torque (permitted 1000 times during the service life of the gearhead)	T_{2Not}	Nm	400	500	500	450	400	500	500	500	500	500	500	500	500	450	400		
		in.lb	3540	4425	4425	3983	3540	4425	4425	4425	4425	4425	4425	4425	4425	3983	3540		
Nominal input speed (with T_{2N} and 20 °C ambient temperature) ^{b), c)}	n_{1N}	rpm	1700	1800	2000	1800	1800	2900	2900	2900	2900	2900	2900	2900	3200	3200	3900		
Max. continuous speed (with 20% T_{2N} and 20 °C ambient temperature)	n_{1Ncym}	rpm	2200	2500	2800	2500	2500	4000	4000	4000	4000	4000	4000	4000	4200	4200	4200		
Max. input speed	n_{1Max}	rpm	4500	4500	4500	4500	4500	4500	4500	4500	4500	4500	4500	4500	4500	4500	4500		
Mean no load running torque (with $n_1=3000$ rpm and 20 °C gearhead temperature) ^{d)}	$T_{01/2}$	Nm	8.4	6.2	5.4	9.0	6.6	1.7	1.1	0.8	0.6	0.6	0.5	0.5	0.4	0.4	0.4		
		in.lb	74	55	48	80	58	15.0	9.7	7.1	5.3	5.3	4.4	4.4	3.5	3.5	3.5		
Max. torsional backlash	j_t	arcmin	≤ 4																
Torsional rigidity	C_{t21}	Nm/arcmin	36	40	46	44	42	40	40	40	40	40	40	40	46	44	42		
		in.lb/arcmin	315	356	405	387	376	356	356	356	356	356	356	356	405	387	376		
Max. axial force ^{e)}	F_{2AMax}	N	9900																
		lb _f	2228																
Max. radial force ^{e)}	F_{2RMMax}	N	9500																
		lb _f	2138																
Max. tilting moment	M_{2KMMax}	Nm	1692																
		in.lb	14974																
Efficiency at full load	η	%	96					94											
Service life (For calculation, see the Chapter "Information")	L_h	h	> 20000																
Weight incl. standard adapter plate	<i>m</i>	kg	22					26											
		lb _m	49					57											
Operating noise (with $n_1 = 3000$ rpm no load)	L_{PA}	dB(A)	≤ 68																
Max. permitted housing temperature	°C		+90																
	F		194																
Ambient temperature	°C		0 to +40																
	F		32 to 104																
Lubrication	Lubricated for life																		
Paint	Blue RAL 5002																		
Direction of rotation	Motor and gearhead opposite directions																		
Protection class	IP 65																		
Moment of inertia (relates to the drive)	G	24	J_1	kgcm ²	-	-	-	-	-	4.43	3.97	3.36	3.22	2.82	2.75	2.50	2.47	2.44	2.42
				10 ⁻³ in.lb.in ²	-	-	-	-	-	3.92	3.51	2.97	2.85	2.50	2.44	2.22	2.18	2.16	2.14
Clamping hub diameter [mm]	K	38	J_1	kgcm ²	28.4	21.0	17.6	14.7	13.1	11.3	10.9	10.3	10.1	9.74	9.66	9.41	9.38	9.35	9.33
				10 ⁻³ in.lb.in ²	25.1	18.6	15.5	13.0	11.6	10.0	9.63	9.09	8.96	8.62	8.55	8.33	8.30	8.28	8.26

Please contact us for information on the best configuration for S1 conditions of use (continuous operation).

^{a)} Other ratios available on request

^{b)} Higher speeds are possible if the nominal torque is reduced

^{c)} For higher ambient temperatures, please reduce input speed

^{d)} Idling torques decrease during operation

^{e)} Refers to center of the output shaft or flange

All technical data for front output side applies.

Technical data for rearward output versions, see page 386.

View A

1-stage:

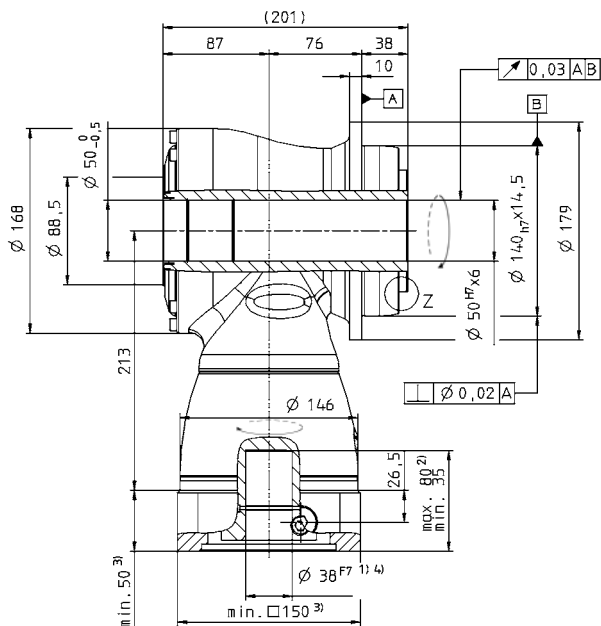
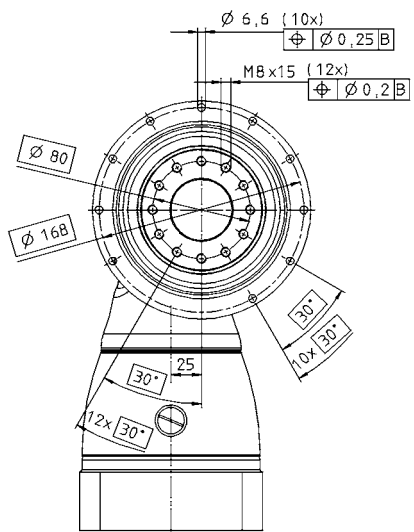

2-stage:

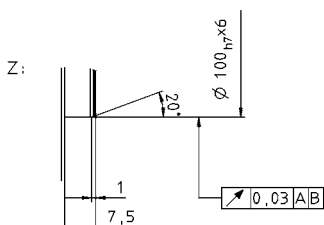
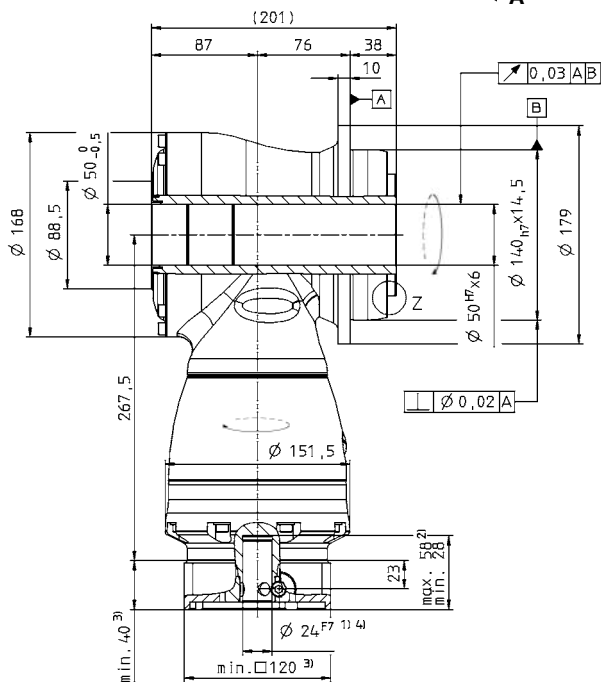
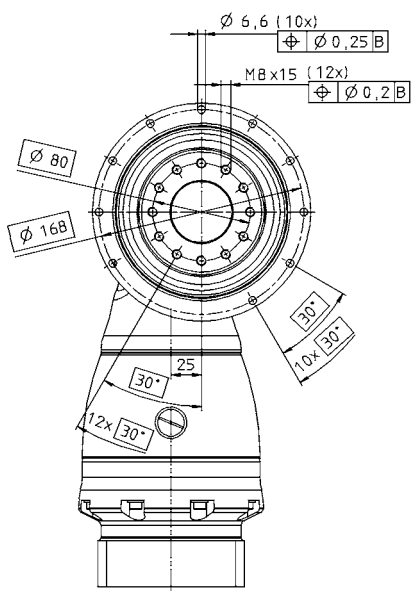

See technical data sheet for available clamping hub diameters (mass moment of inertia). Dimensions available on request.

Non-tolerated dimensions ± 1 mm

- 1) Check motor shaft fit.
- 2) Min./Max. permissible motor shaft length. Longer motor shafts are adaptable, please contact us.
- 3) The dimensions depend on the motor.
- 4) Smaller motor shaft diameter is compensated by a bushing with a minimum thickness of 1 mm.

CAD data is available under www.wittenstein-alpha.com

Motor mounting according to operating manual

TK+ 110 MF 1/2-stage

		1-stage					2-stage												
Ratio ^{a)}	<i>i</i>	3	4	5	7	10	12	16	20	25	28	35	40	50	70	100			
Max. acceleration torque (max. 1000 cycles per hour)	T_{2B}	Nm	640	640	640	550	470	640	640	640	640	640	640	640	640	550	470		
		in.lb	5664	5664	5664	4868	4160	5664	5664	5664	5664	5664	5664	5664	5664	4868	4160		
Nominal output torque (with n_m)	T_{2N}	Nm	400	400	400	380	360	400	400	400	400	400	400	400	400	380	360		
		in.lb	3540	3540	3540	3363	3186	3540	3540	3540	3540	3540	3540	3540	3540	3363	3186		
Emergency stop torque (permitted 1000 times during the service life of the gearhead)	T_{2Not}	Nm	900	1050	1050	970	900	1050	1050	1050	1050	1050	1050	1050	1050	970	900		
		in.lb	7965	9293	9293	8585	7965	9293	9293	9293	9293	9293	9293	9293	9293	8585	7965		
Nominal input speed (with T_{2N} and 20 °C ambient temperature) ^{b), c)}	n_{1N}	rpm	1400	1600	1800	1600	1600	2700	2700	2700	2700	2700	2700	2700	2900	3200	3400		
Max. continuous speed (with 20% T_{2N} and 20 °C ambient temperature)	n_{1Ncym}	rpm	1800	2100	2500	2200	2200	3500	3500	3500	3500	3500	3500	3500	3500	3800	3800		
Max. input speed	n_{1Max}	rpm	4000	4000	4000	4000	4000	4000	4000	4000	4000	4000	4000	4000	4000	4000	4000		
Mean no load running torque (with $n_1=3000$ rpm and 20 °C gearhead temperature) ^{d)}	$T_{01/2}$	Nm	17.5	14.5	12.0	18.0	15.0	3.6	2.8	2.2	1.9	1.6	1.4	1.1	1.1	1.1	1.1		
		in.lb	155	128	106	159	133	31.9	24.8	19.5	16.8	14.2	12.4	9.7	9.7	9.7	9.7		
Max. torsional backlash	j_t	arcmin	≤ 4																
Torsional rigidity	C_{t21}	Nm/arcmin	76	87	99	97	96	87	87	87	87	87	87	87	99	97	96		
		in.lb/arcmin	676	766	874	860	847	766	766	766	766	766	766	766	766	874	860	847	
Max. axial force ^{e)}	F_{2AMax}	N	14200																
		lb _f	3195																
Max. radial force ^{e)}	F_{2RMax}	N	14700																
		lb _f	3308																
Max. tilting moment	M_{2KMax}	Nm	3213																
		in.lb	28435																
Efficiency at full load	η	%	96					94											
Service life (For calculation, see the Chapter "Information")	L_h	h	> 20000																
Weight incl. standard adapter plate	<i>m</i>	kg	48					54											
		lb _m	106					119											
Operating noise (with $n_1=3000$ rpm no load)	L_{PA}	dB(A)	≤ 68																
Max. permitted housing temperature		°C	+90																
		F	194																
Ambient temperature		°C	0 to +40																
		F	32 to 104																
Lubrication			Lubricated for life																
Paint			Blue RAL 5002																
Direction of rotation			Motor and gearhead opposite directions																
Protection class			IP 65																
Moment of inertia (relates to the drive) Clamping hub diameter [mm]	K	38	J_1	kgcm ²	-	-	-	-	-	16.8	14.8	12.9	12.3	11.2	10.9	10.3	10.1	10.0	9.93
				10 ³ in.lb.s ²	-	-	-	-	-	14.8	13.1	11.4	10.9	9.88	9.63	9.08	8.95	8.84	8.79
	M	48	J_1	kgcm ²	96.5	64.6	50.5	38.2	31.8	31.5	29.5	27.6	27.0	25.9	25.6	25.0	24.8	24.7	24.6
				10 ³ in.lb.s ²	85.4	57.2	44.7	33.8	28.1	27.9	26.1	24.4	23.9	22.9	22.6	22.1	22.0	21.9	21.8

Please contact us for information on the best configuration for S1 conditions of use (continuous operation).

^{a)} Other ratios available on request

^{b)} Higher speeds are possible if the nominal torque is reduced

^{c)} For higher ambient temperatures, please reduce input speed

^{d)} Idling torques decrease during operation

^{e)} Refers to center of the output shaft or flange

All technical data for front output side applies.

Technical data for rearward output versions, see page 386.

View A

1-stage:

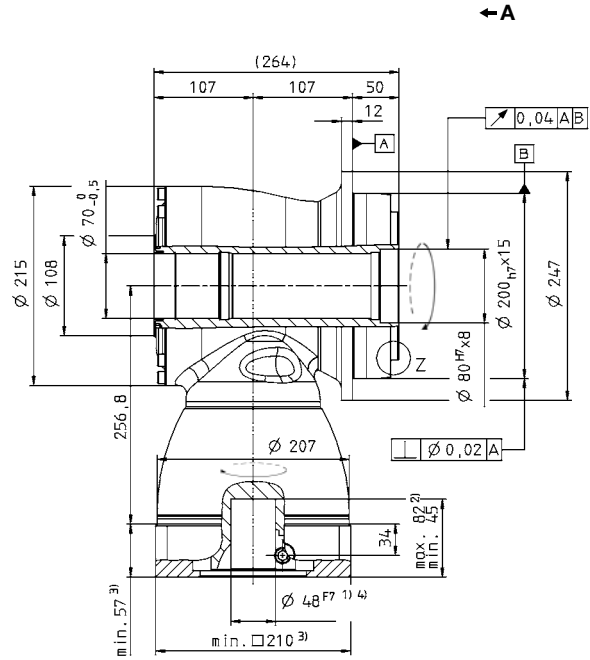
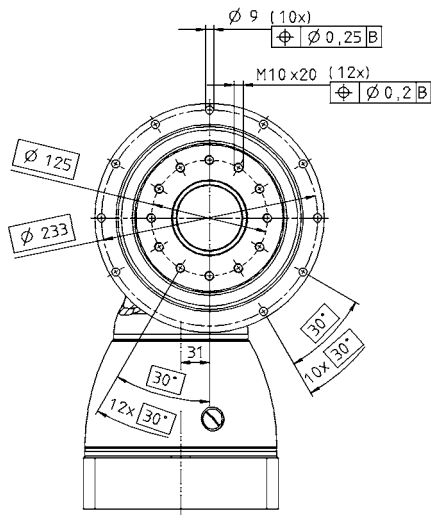

2-stage:

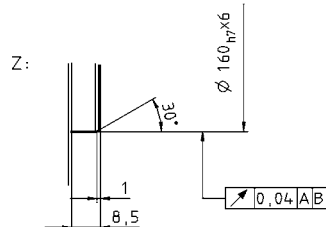
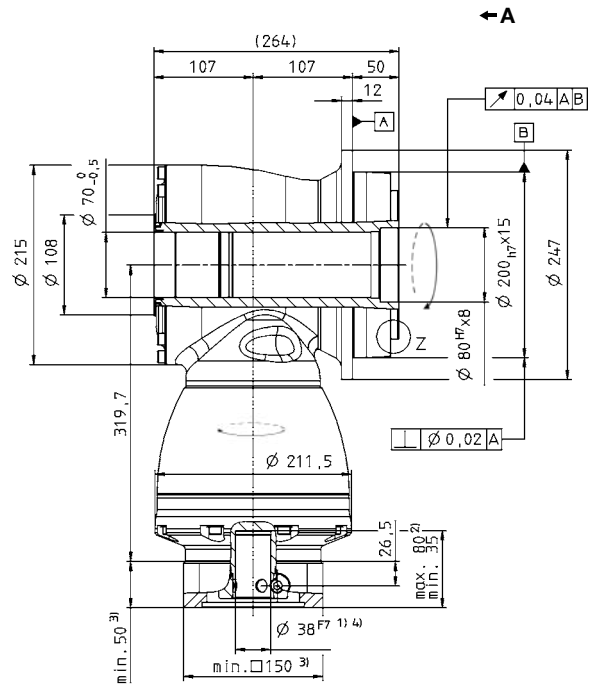
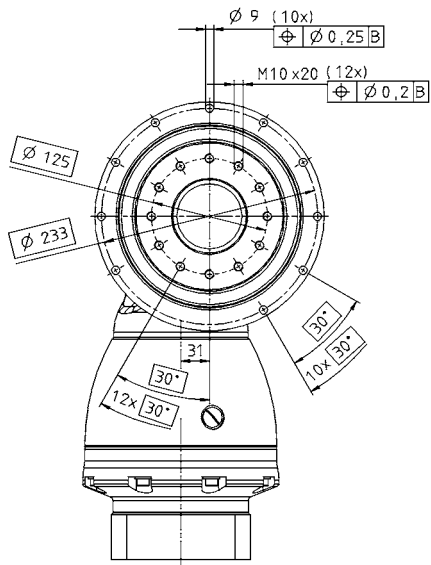

See technical data sheet for available clamping hub diameters (mass moment of inertia). Dimensions available on request.

Non-tolerated dimensions ± 1 mm

- 1) Check motor shaft fit.
- 2) Min./Max. permissible motor shaft length. Longer motor shafts are adaptable, please contact us.
- 3) The dimensions depend on the motor.
- 4) Smaller motor shaft diameter is compensated by a bushing with a minimum thickness of 1 mm.

CAD data is available under www.wittenstein-alpha.com

Motor mounting according to operating manual

TPK+ 010 MF 2-stage

		2-stage													
Ratio ^{a)}	<i>i</i>		12	16	20	25	28	35	40	49	50	70	100		
Max. acceleration torque (max. 1000 cycles per hour)	T_{2B}	Nm	120	120	130	130	130	130	80	130	100	130	100		
		in.lb	1.062	1.062	1.151	1.151	1.151	1.151	708	1.151	885	1.151	885		
Nominal output torque (with n_{in})	T_{2N}	Nm	75	75	75	75	75	75	60	75	75	75	60		
		in.lb	664	664	664	664	664	664	531	664	664	664	531		
Emergency stop torque (permitted 1000 times during the service life of the gearhead)	T_{2Not}	Nm	160	200	250	250	250	250	160	250	200	250	250		
		in.lb	1416	1770	2213	2213	2213	2213	1416	2213	1770	2213	2213		
Nominal input speed (with T_{2N} and 20 °C ambient temperature) ^{b), c)}	n_{1N}	rpm	2000	2400	2400	2700	2400	2500	2500	2500	2500	2500	2500		
Max. continuous speed (with 20% T_{2N} and 20 °C ambient temperature)	n_{1Ncym}	rpm	3000	3400	3400	3800	3400	3200	3200	3200	3200	3200	3200		
Max. input speed	n_{1Max}	rpm	6000	6000	6000	6000	6000	6000	6000	6000	6000	6000	6000		
Mean no load running torque (with $n_1=3000$ rpm and 20 °C gearhead temperature) ^{d)}	$T_{01/2}$	Nm	1.5	1.3	1.2	1.2	1.2	1.3	1.3	1.3	1.3	1.3	1.3		
		in.lb	13.3	11.5	10.6	10.6	10.6	11.5	11.5	11.5	11.5	11.5	11.5		
Max. torsional backlash	j_t	arcmin	Standard ≤ 5 / Reduced ≤ 3												
Torsional rigidity	C_{t21}	Nm/ arcmin	16	16	20	21	23	24	15	23	19	22	27		
		in.lb/ arcmin	142	142	177	186	204	212	133	204	168	195	239		
Tilting rigidity	C_{2K}	Nm/ arcmin	225												
		in.lb/ arcmin	1991												
Max. axial force ^{e)}	F_{2AMax}	N	2150												
		lb _f	484												
Max. tilting moment	M_{2KMax}	Nm	235												
		in.lb	2080												
Efficiency at full load	η	%	94												
Service life (For calculation, see the Chapter "Information")	L_n	h	> 20000												
Weight incl. standard adapter plate	<i>m</i>	kg	5.2												
		lb _m	11.5												
Operating noise (with $n_1=3000$ rpm no load)	L_{PA}	dB(A)	≤ 66												
Max. permitted housing temperature		°C	+90												
		F	194												
Ambient temperature		°C	0 to +40												
		F	32 to 104												
Lubrication			Lubricated for life												
Paint			Blue RAL 5002												
Direction of rotation			Motor and gearhead opposite directions												
Protection class			IP 65												
Moment of inertia (relates to the drive) Clamping hub diameter [mm]	C	14	J_f	kgcm ²	0.55	0.46	0.44	0.39	0.43	0.36	0.34	0.37	0.34	0.34	0.34
				10 ⁻³ in.lb.in ²	0.49	0.40	0.39	0.35	0.38	0.32	0.30	0.33	0.30	0.30	0.30
	E	19	J_f	kgcm ²	0.90	0.81	0.79	0.75	0.78	0.71	0.70	0.72	0.70	0.69	0.69
				10 ⁻³ in.lb.in ²	0.80	0.72	0.70	0.66	0.69	0.63	0.62	0.64	0.62	0.61	0.61

Please contact us for information on the best configuration for S1 conditions of use (continuous operation).

^{a)} Other ratios up to $i=1000$ available on request

^{b)} Higher speeds are possible if the nominal torque is reduced

^{c)} For higher ambient temperatures, please reduce input speed

^{d)} Idling torques decrease during operation

^{e)} Refers to center of the output shaft or flange

All technical data for front output side applies.

Technical data for rearward output versions, see page 386.

View A

2-stage:

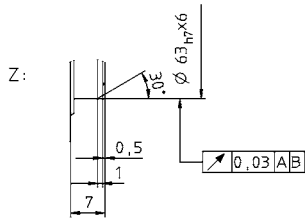
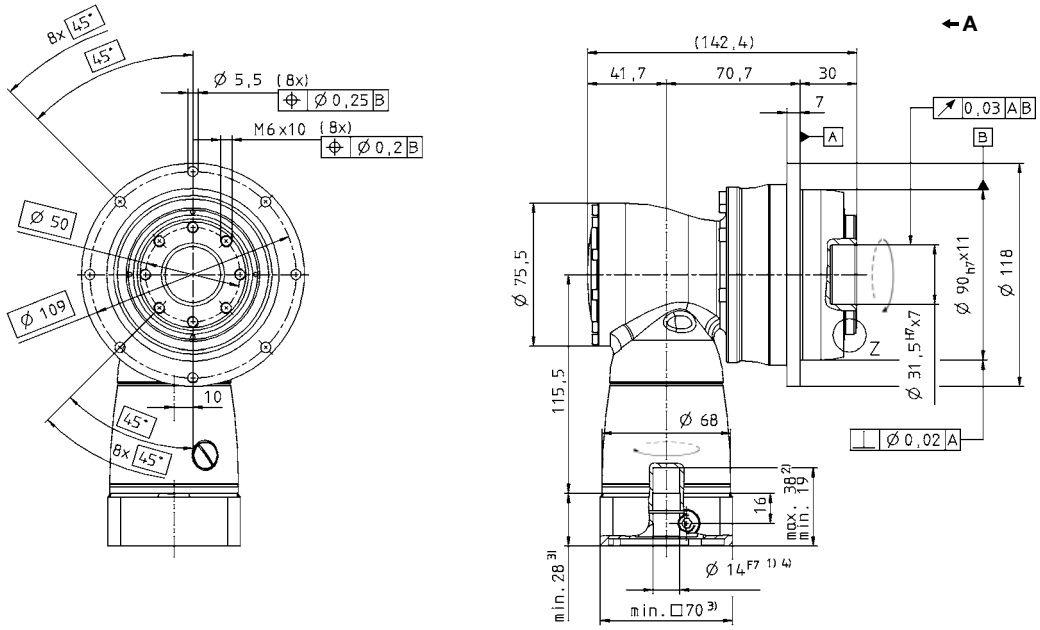

See technical data sheet for available clamping hub diameters (mass moment of inertia). Dimensions available on request.

Non-tolerated dimensions ±1 mm

- 1) Check motor shaft fit.
- 2) Min./Max. permissible motor shaft length. Longer motor shafts are adaptable, please contact us.
- 3) The dimensions depend on the motor.
- 4) Smaller motor shaft diameter is compensated by a bushing with a minimum thickness of 1 mm.

CAD data is available under www.wittenstein-alpha.com

Motor mounting according to operating manual

TPK+ 010 MF 3-stage

		3-stage														
Ratio ^{a)}		<i>i</i>	64	84	100	125	140	175	200	250	280	350	400	500	700	1000
Max. acceleration torque (max. 1000 cycles per hour)	T_{2B}	Nm	120	120	130	130	130	130	130	130	130	130	80	100	130	100
		in.lb	1062	1062	1151	1151	1151	1151	1151	1151	1151	1151	708	885	1151	885
Nominal output torque (with n_m)	T_{2N}	Nm	85	85	90	90	90	90	90	90	75	90	60	75	90	60
		in.lb	752	752	797	797	797	797	797	797	664	797	531	664	797	531
Emergency stop torque (permitted 1000 times during the service life of the gearhead)	T_{2Not}	Nm	200	160	250	250	250	250	250	250	250	250	160	200	250	250
		in.lb	1770	1416	2213	2213	2213	2213	2213	2213	2213	2213	1416	1770	2213	2213
Nominal input speed (with T_{2N} and 20 °C ambient temperature) ^{b), c)}	n_{1N}	rpm	4400	4400	4400	4400	4400	4400	4400	4800	4400	4800	5500	5500	5500	5500
Max. continuous speed (with 20% T_{2N} and 20 °C ambient temperature)	n_{1Nsym}	rpm	5000	5000	5000	5000	5000	5000	5000	5000	5000	5500	5500	5500	5500	5500
Max. input speed	n_{1Max}	rpm	6000	6000	6000	6000	6000	6000	6000	6000	6000	6000	6000	6000	6000	6000
Mean no load running torque (with $n_1=3000$ rpm and 20 °C gearhead temperature) ^{d)}	T_{012}	Nm	0.3	0.3	0.3	0.3	0.3	0.3	0.2	0.2	0.2	0.2	0.2	0.2	0.2	0.2
		in.lb	2.7	2.7	2.7	2.7	2.7	2.7	1.8	1.8	1.8	1.8	1.8	1.8	1.8	1.8
Max. torsional backlash	j_t	arcmin	Standard ≤ 5 / Reduced ≤ 3													
Torsional rigidity	C_{t21}	Nm/ arcmin	16	16	20	21	20	21	20	21	23	24	15	19	22	27
		in.lb/ arcmin	142	142	177	186	177	186	177	186	204	212	133	168	195	239
Tilting rigidity	C_{2K}	Nm/ arcmin	225													
		in.lb/ arcmin	1991													
Max. axial force ^{e)}	F_{2AMax}	N	2150													
		lb _f	484													
Max. tilting moment	M_{2KMax}	Nm	235													
		in.lb	2080													
Efficiency at full load	η	%	92													
Service life (For calculation, see the Chapter "Information")	L_h	h	> 20000													
Weight incl. standard adapter plate	<i>m</i>	kg	5,5													
		lb _m	12,2													
Operating noise (with $n_1=3000$ rpm no load)	L_{PA}	dB(A)	≤ 66													
Max. permitted housing temperature		°C	90													
		F	194													
Ambient temperature		°C	0 to +40													
		F	32 to 104													
Lubrication			Lubricated for life													
Paint			Blue RAL 5002													
Direction of rotation			Motor and gearhead opposite directions													
Protection class			IP 65													
Moment of inertia (relates to the drive) Clamping hub diameter [mm]	B 11	J_1	kgcm ²	0.09	0.07	0.08	0.07	0.06	0.06	0.06	0.06	0.06	0.06	0.06	0.06	0.06
			10 ³ in.lb.in ²	0.08	0.06	0.07	0.06	0.05	0.05	0.05	0.05	0.05	0.05	0.05	0.05	0.05
	C 14	J_1	kgcm ²	0.20	0.18	0.19	0.19	0.18	0.18	0.17	0.17	0.17	0.17	0.17	0.17	0.17
			10 ³ in.lb.in ²	0.18	0.16	0.17	0.17	0.16	0.16	0.15	0.15	0.15	0.15	0.15	0.15	0.15

Please contact us for information on the best configuration for S1 conditions of use (continuous operation).

- ^{a)} Other ratios available on request
- ^{b)} Higher speeds are possible if the nominal torque is reduced
- ^{c)} For higher ambient temperatures, please reduce input speed
- ^{d)} Idling torques decrease during operation
- ^{e)} Refers to center of the output shaft or flange

All technical data for front output side applies.
Technical data for rearward output versions, see page 386.

View A

3-stage:

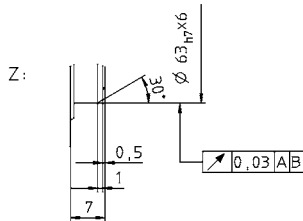
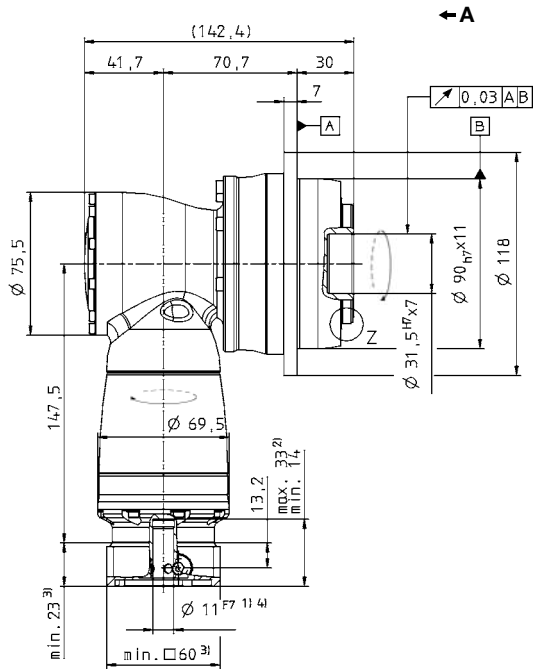
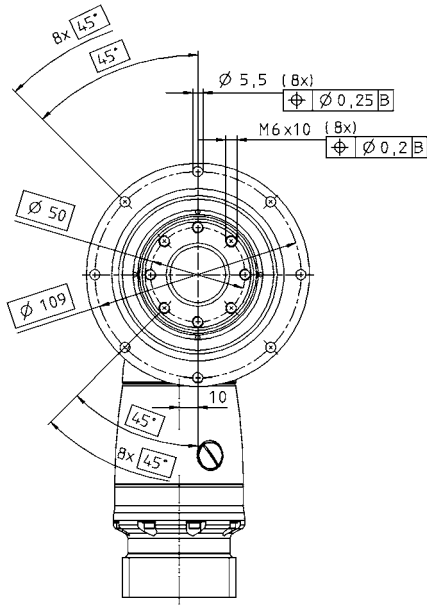

See technical data sheet for available clamping hub diameters (mass moment of inertia). Dimensions available on request.

Non-tolerated dimensions ± 1 mm

- 1) Check motor shaft fit.
- 2) Min./Max. permissible motor shaft length. Longer motor shafts are adaptable, please contact us.
- 3) The dimensions depend on the motor.
- 4) Smaller motor shaft diameter is compensated by a bushing with a minimum thickness of 1 mm.

CAD data is available under www.wittenstein-alpha.com

Motor mounting according to operating manual

TPK+ 025 MF 2-stage

		2-stage													
Ratio ^{a)}	<i>i</i>		12	16	20	25	28	35	40	49	50	70	100		
Max. acceleration torque (max. 1000 cycles per hour)	T_{2B}	Nm	280	280	350	350	350	330	330	330	265	400	400		
		in.lb	2478	2478	3098	3098	3098	2921	1770	2921	2213	2921	2345		
Nominal output torque (with n_m)	T_{2N}	Nm	170	170	170	170	170	170	160	170	170	170	120		
		in.lb	1505	1505	1505	1505	1505	1505	1416	1505	1505	1505	1062		
Emergency stop torque (permitted 1000 times during the service life of the gearhead)	T_{2Not}	Nm	400	575	575	500	625	625	400	625	500	625	625		
		in.lb	3540	5089	5089	5089	5531	5531	3540	5531	4425	5531	5531		
Nominal input speed (with T_{2N} and 20 °C ambient temperature) ^{b), c)}	n_{1N}	rpm	2000	2400	2400	2700	2400	2500	2500	2500	2500	2500	2500		
Max. continuous speed (with 20% T_{2N} and 20 °C ambient temperature)	n_{1Ncym}	rpm	3000	3400	3400	3800	3400	3200	3200	3200	3200	3200	3200		
Max. input speed	n_{1Max}	rpm	6000	6000	6000	6000	6000	6000	6000	6000	6000	6000	6000		
Mean no load running torque (with $n_1=3000$ rpm and 20 °C gearhead temperature) ^{d)}	$T_{01/2}$	Nm	2.5	2.1	2.0	1.8	2.0	1.8	2.0	2.2	2.0	2.0	2.0		
		in.lb	22.1	18.6	17.7	15.9	17.7	15.9	17.7	19.5	17.7	17.7	17.7		
Max. torsional backlash	j_t	arcmin	Standard ≤ 4 / Reduced ≤ 2												
Torsional rigidity	C_{t21}	Nm/ arcmin	40	42	53	55	59	60	44	60	55	60	56		
		in.lb/ arcmin	354	372	469	487	522	531	389	531	487	531	496		
Tilting rigidity	C_{2K}	Nm/ arcmin	550												
		in.lb/ arcmin	4868												
Max. axial force ^{e)}	F_{2AMax}	N	4150												
		lb _f	934												
Max. tilting moment	M_{2KMax}	Nm	413												
		in.lb	3655												
Efficiency at full load	η	%	94												
Service life (For calculation, see the Chapter "Information")	L_h	h	> 20000												
Weight incl. standard adapter plate	<i>m</i>	kg	9.0												
		lb _m	19.9												
Operating noise (with $n_1 = 3000$ rpm no load)	L_{PA}	dB(A)	≤ 68												
Max. permitted housing temperature		°C	+90												
		F	194												
Ambient temperature		°C	0 to +40												
		F	32 to 104												
Lubrication			Lubricated for life												
Paint			Blue RAL 5002												
Direction of rotation			Motor and gearhead opposite directions												
Protection class			IP 65												
Moment of inertia (relates to the drive) Clamping hub diameter [mm]	E	19	J_1	kgcm ²	1.43	1.18	1.16	1.04	1.14	0.94	0.89	0.95	0.89	0.89	0.89
				10 ⁻³ in.lb.s ²	1.27	1.04	1.02	0.92	1.01	0.83	0.79	0.84	0.79	0.79	0.78
	H	28	J_1	kgcm ²	2.85	2.59	2.57	2.45	2.56	2.40	2.31	2.37	2.30	2.30	2.30
				10 ⁻³ in.lb.s ²	2.52	2.29	2.27	2.17	2.26	2.08	2.04	2.10	2.04	2.04	2.04

Please contact us for information on the best configuration for S1 conditions of use (continuous operation).

^{a)} Other ratios up to $i=1000$ available on request

^{b)} Higher speeds are possible if the nominal torque is reduced

^{c)} For higher ambient temperatures, please reduce input speed

^{d)} Idling torques decrease during operation

^{e)} Refers to center of the output shaft or flange

All technical data for front output side applies.

Technical data for rearward output versions, see page 386.

View A

2-stage:

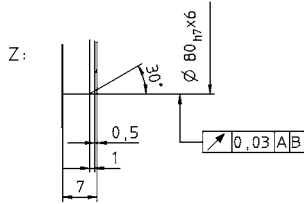
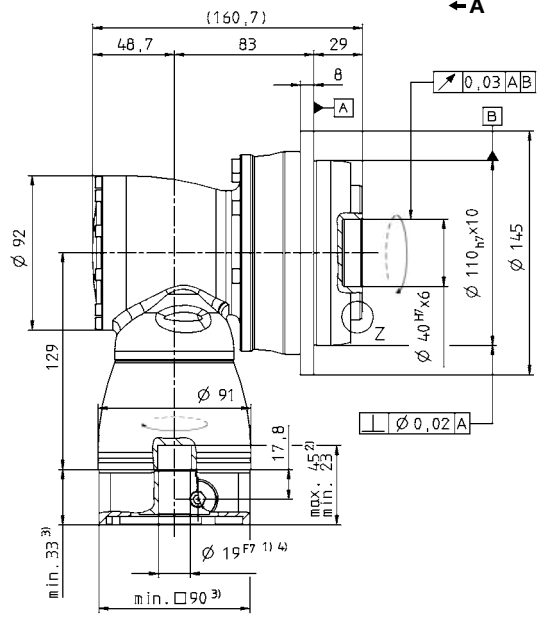
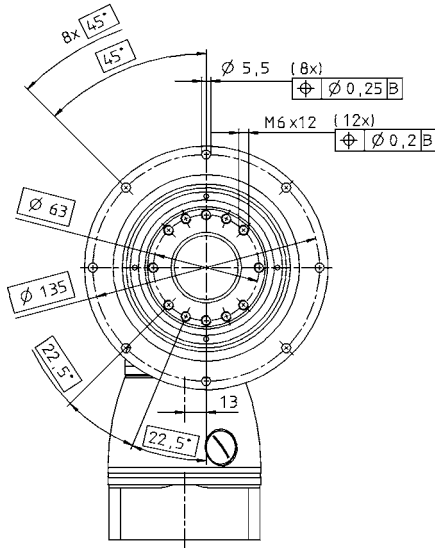

See technical data sheet for available clamping hub diameters (mass moment of inertia). Dimensions available on request.

Non-tolerated dimensions ± 1 mm

- 1) Check motor shaft fit.
- 2) Min./Max. permissible motor shaft length. Longer motor shafts are adaptable, please contact us.
- 3) The dimensions depend on the motor.
- 4) Smaller motor shaft diameter is compensated by a bushing with a minimum thickness of 1 mm.

CAD data is available under www.wittenstein-alpha.com

Motor mounting according to operating manual

TPK+ 025 MF 3-stage

		3-stage															
Ratio ^{a)}		<i>i</i>	64	84	100	125	140	175	200	250	280	350	400	500	700	1000	
Max. acceleration torque (max. 1000 cycles per hour)	T_{2B}	Nm	280	280	350	350	350	350	350	350	350	330	200	250	330	265	
		in.lb	2478	2478	3098	3098	3098	3098	3098	3098	3098	3098	2921	1770	2213	2921	2345
Nominal output torque (with n_m)	T_{2N}	Nm	200	170	200	200	200	200	200	200	210	200	160	200	200	120	
		in.lb	1770	1505	1770	1770	1770	1770	1770	1770	1859	1770	1416	1770	1770	1062	
Emergency stop torque (permitted 1000 times during the service life of the gearhead)	T_{2Not}	Nm	460	400	575	575	575	575	575	575	625	625	400	500	625	625	
		in.lb	4071	3540	5089	5089	5089	5089	5089	5089	5531	5531	3540	4425	5531	5531	
Nominal input speed (with T_{2N} and 20 °C ambient temperature) ^{b), c)}	n_{1N}	rpm	3500	3500	3500	3500	3500	3500	3500	3800	3500	3800	4500	4500	4500	4500	
Max. continuous speed (with 20% T_{2N} and 20 °C ambient temperature)	n_{1Nsym}	rpm	4500	4500	4500	4500	4500	4500	4500	4500	4500	4500	4500	4500	4500	4500	
Max. input speed	n_{1Max}	rpm	6000	6000	6000	6000	6000	6000	6000	6000	6000	6000	6000	6000	6000	6000	
Mean no load running torque (with $n_1=3000$ rpm and 20 °C gearhead temperature) ^{d)}	T_{012}	Nm	0.4	0.3	0.3	0.3	0.3	0.3	0.2	0.2	0.2	0.2	0.2	0.2	0.2	0.2	
		in.lb	3.5	2.7	2.7	2.7	2.7	2.7	1.8	1.8	1.8	1.8	1.8	1.8	1.8	1.8	
Max. torsional backlash	j_t	arcmin	Standard ≤ 4 / Reduced ≤ 2														
Torsional rigidity	C_{t21}	Nm/ arcmin	42	40	53	55	53	55	53	55	59	60	44	55	60	56	
		in.lb/ arcmin	372	354	469	487	469	487	469	487	522	531	389	487	531	496	
Tilting rigidity	C_{2K}	Nm/ arcmin	550														
		in.lb/ arcmin	4868														
Max. axial force ^{e)}	F_{2AMax}	N	4150														
		lb _f	934														
Max. tilting moment	M_{2KMax}	Nm	413														
		in.lb	3655														
Efficiency at full load	η	%	92														
Service life (For calculation, see the Chapter "Information")	L_h	h	> 20000														
Weight incl. standard adapter plate	<i>m</i>	kg	9,8														
		lb _m	21,7														
Operating noise (with $n_1=3000$ rpm no load)	L_{PA}	dB(A)	≤ 68														
Max. permitted housing temperature		°C	90														
		F	194														
Ambient temperature		°C	0 to +40														
		F	32 to 104														
Lubrication			Lubricated for life														
Paint			Blue RAL 5002														
Direction of rotation			Motor and gearhead opposite directions														
Protection class			IP 65														
Moment of inertia (relates to the drive) Clamping hub diameter [mm]	C	14	J_1	kgcm ²	0.28	0.23	0.24	0.23	0.21	0.20	0.19	0.18	0.19	0.18	0.18	0.18	0.18
				10 ⁻³ in.lb.in ²	0.25	0.20	0.21	0.20	0.19	0.18	0.17	0.16	0.17	0.16	0.16	0.16	0.16
	E	19	J_1	kgcm ²	0.72	0.63	0.68	0.68	0.63	0.63	0.63	0.63	0.63	0.63	0.63	0.63	0.63
				10 ⁻³ in.lb.in ²	0.64	0.56	0.60	0.60	0.56	0.56	0.56	0.56	0.56	0.56	0.56	0.56	0.56

Please contact us for information on the best configuration for S1 conditions of use (continuous operation).

- ^{a)} Other ratios available on request
- ^{b)} Higher speeds are possible if the nominal torque is reduced
- ^{c)} For higher ambient temperatures, please reduce input speed
- ^{d)} Idling torques decrease during operation
- ^{e)} Refers to center of the output shaft or flange

All technical data for front output side applies.
Technical data for rearward output versions, see page 386.

View A

3-stage:

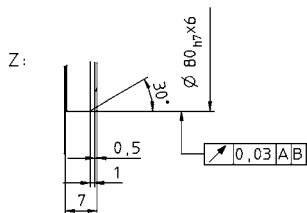
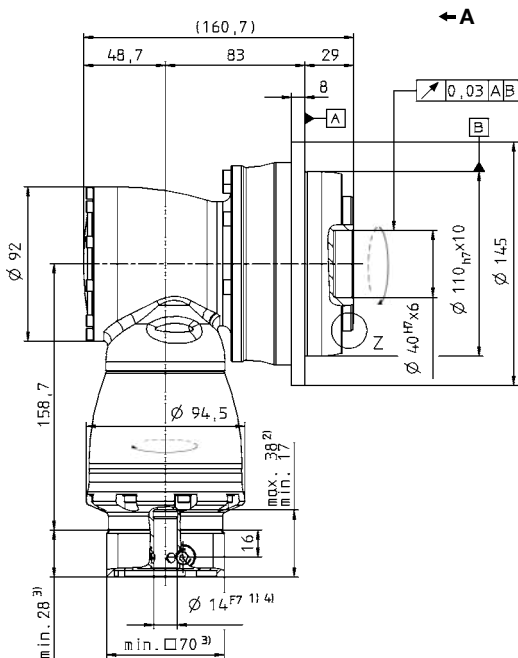
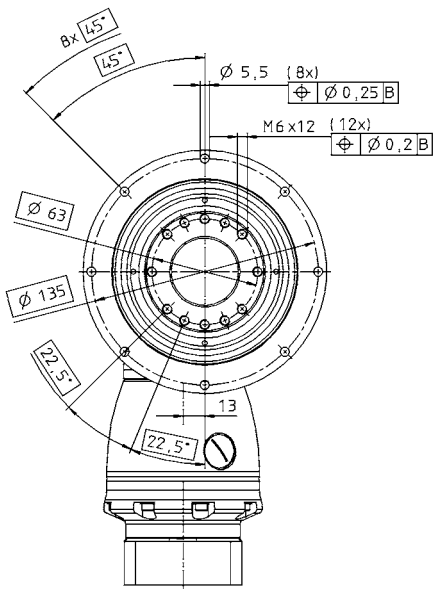

Right-angle gearheads
High End

TPK+

MF

See technical data sheet for available clamping hub diameters (mass moment of inertia). Dimensions available on request.

Non-tolerated dimensions ± 1 mm

- 1) Check motor shaft fit.
- 2) Min./Max. permissible motor shaft length. Longer motor shafts are adaptable, please contact us.
- 3) The dimensions depend on the motor.
- 4) Smaller motor shaft diameter is compensated by a bushing with a minimum thickness of 1 mm.

CAD data is available under www.wittenstein-alpha.com

Motor mounting according to operating manual

TPK+ 050 MF 2-stage

		2-stage													
Ratio ^{a)}		<i>i</i>	12	16	20	25	28	35	40	49	50	70	100		
Max. acceleration torque (max. 1000 cycles per hour)	T_{2B}	Nm	680	680	750	750	700	700	500	700	625	700	540		
		in.lb	6018	6018	6638	6638	6195	6416	4425	6195	5531	6195	4779		
Nominal output torque (with n_m)	T_{2N}	Nm	370	370	370	370	370	370	320	370	370	370	240		
		in.lb	3275	3275	3275	3275	3275	3275	2832	3275	3275	3275	2124		
Emergency stop torque (permitted 1000 times during the service life of the gearhead)	T_{2Not}	Nm	1000	1000	1250	1250	1250	1250	1000	1250	1250	1250	1250		
		in.lb	8850	8850	11063	11063	11063	11063	8850	11063	11063	11063	11063		
Nominal input speed (with T_{2N} and 20 °C ambient temperature) ^{b), c)}	n_{1N}	rpm	1900	2300	2300	2600	2300	2300	2300	2300	2300	2300	2300		
Max. continuous speed (with 20% T_{2N} and 20 °C ambient temperature)	n_{1Ncym}	rpm	2700	3100	3100	3500	3100	3000	3000	3000	3000	3000	3000		
Max. input speed	n_{1Max}	rpm	4500	4500	4500	4500	4500	4500	4500	4500	4500	4500	4500		
Mean no load running torque (with $n_1=3000$ rpm and 20 °C gearhead temperature) ^{d)}	$T_{01/2}$	Nm	4.0	3.7	3.6	2.8	3.5	2.8	3.1	3.9	3.1	3.1	3.1		
		in.lb	35.4	32.7	31.9	24.8	31.0	24.8	27.4	34.5	27.4	27.4	27.4		
Max. torsional backlash	j_t	arcmin	Standard ≤ 4 / Reduced ≤ 2												
Torsional rigidity	C_{t21}	Nm/ arcmin	87	91	111	119	123	127	96	127	115	125	112		
		in.lb/ arcmin	770	805	982	1053	1089	1124	850	1124	1018	1106	991		
Tilting rigidity	C_{2K}	Nm/ arcmin	560												
		in.lb/ arcmin	4956												
Max. axial force ^{e)}	F_{2AMax}	N	6130												
		lb _f	1379												
Max. tilting moment	M_{2KMax}	Nm	1295												
		in.lb	11461												
Efficiency at full load	η	%	94												
Service life (For calculation, see the Chapter "Information")	L_h	h	> 20000												
Weight incl. standard adapter platee	<i>m</i>	kg	17.0												
		lb _m	38												
Operating noise (with $n_1 = 3000$ rpm no load)	L_{PA}	dB(A)	≤ 68												
Max. permitted housing temperature		°C	+90												
		F	194												
Ambient temperature		°C	0 to +40												
		F	32 to 104												
Lubrication			Lubricated for life												
Paint			Blue RAL 5002												
Direction of rotation			Motor and gearhead opposite directions												
Protection class			IP 65												
Moment of inertia (relates to the drive) Clamping hub diameter [mm]	H	28	J_1	kgcm ²	4.56	3.76	3.71	3.28	3.66	3.00	2.79	3.10	2.78	2.77	2.77
				10 ⁻³ in.lb.s ²	4.04	3.32	3.28	2.90	3.24	2.61	2.47	2.74	2.46	2.45	2.45
	K	38	J_1	kgcm ²	11.7	10.9	10.9	10.4	10.8	10.3	9.95	10.4	9.94	9.94	9.93
				10 ⁻³ in.lb.s ²	10.38	9.67	9.62	9.24	9.58	8.96	8.81	9.20	8.80	8.80	8.79

Please contact us for information on the best configuration for S1 conditions of use (continuous operation).

^{a)} Other ratios up to $i=1000$ available on request

^{b)} Higher speeds are possible if the nominal torque is reduced

^{c)} For higher ambient temperatures, please reduce input speed

^{d)} Idling torques decrease during operation

^{e)} Refers to center of the output shaft or flange

All technical data for front output side applies.

Technical data for rearward output versions, see page 386.

View A

2-stage:

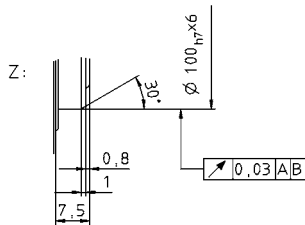
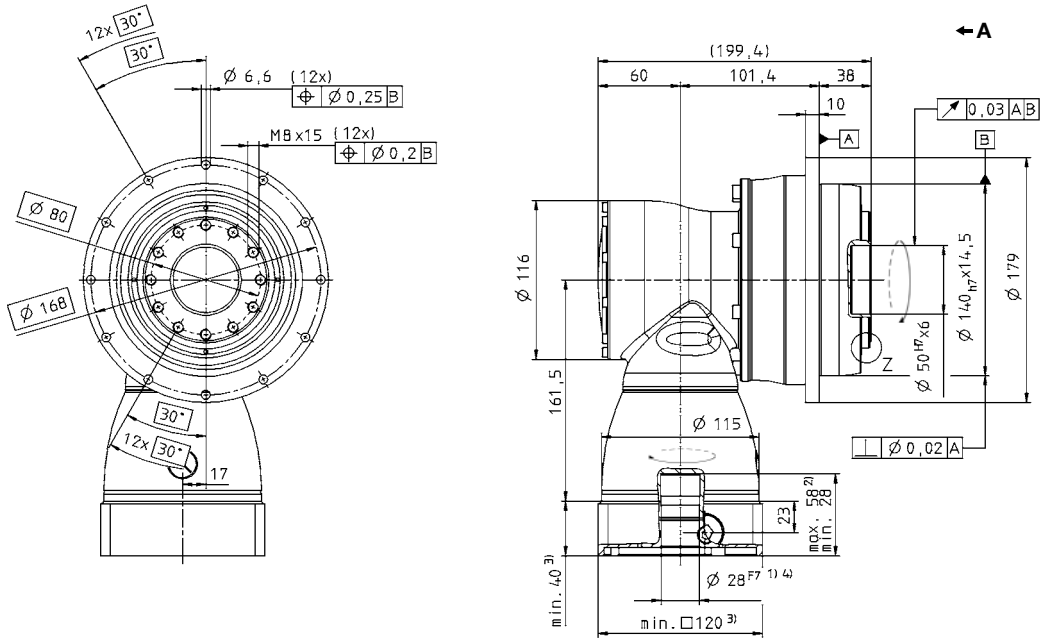

See technical data sheet for available clamping hub diameters (mass moment of inertia). Dimensions available on request.

Non-tolerated dimensions ± 1 mm

- 1) Check motor shaft fit.
- 2) Min./Max. permissible motor shaft length. Longer motor shafts are adaptable, please contact us.
- 3) The dimensions depend on the motor.
- 4) Smaller motor shaft diameter is compensated by a bushing with a minimum thickness of 1 mm.

CAD data is available under www.wittenstein-alpha.com

Motor mounting according to operating manual

TPK+ 050 MF 3-stage

		3-stage															
Ratio ^{a)}		<i>i</i>	64	84	100	125	140	175	200	250	280	350	400	500	700	1000	
Max. acceleration torque (max. 1000 cycles per hour)	T_{2B}	Nm	680	680	750	750	750	750	750	750	700	700	500	625	700	540	
		in.lb	6018	6018	6638	6638	6638	6638	6638	6638	6195	6195	4425	5531	6195	4779	
Nominal output torque (with n_m)	T_{2N}	Nm	400	400	400	400	400	400	400	400	400	400	320	370	400	240	
		in.lb	3540	3540	3540	3540	3540	3540	3540	3540	3540	3540	2832	3275	3540	2124	
Emergency stop torque (permitted 1000 times during the service life of the gearhead)	T_{2Not}	Nm	1000	1000	1250	1250	1250	1250	1250	1250	1250	1250	1000	1250	1250	1250	
		in.lb	8850	8850	11063	11063	11063	11063	11063	11063	11063	11063	8850	11063	11063	11063	
Nominal input speed (with T_{2N} and 20 °C ambient temperature) ^{b), c)}	n_{1N}	rpm	3100	3100	3100	3100	3100	3100	3100	3500	3100	3500	4200	4200	4200	4200	
Max. continuous speed (with 20% T_{2N} and 20 °C ambient temperature)	n_{1Nsym}	rpm	4000	4000	4000	4000	4000	4000	4000	4000	4000	4000	4200	4200	4200	4200	
Max. input speed	n_{1Max}	rpm	4500	4500	4500	4500	4500	4500	4500	4500	4500	4500	4500	4500	4500	4500	
Mean no load running torque (with $n_1=3000$ rpm and 20 °C gearhead temperature) ^{d)}	T_{012}	Nm	0.7	0.4	0.6	0.5	0.5	0.4	0.3	0.3	0.3	0.3	0.3	0.3	0.3	0.3	
		in.lb	6.2	3.5	5.3	4.4	4.4	3.5	2.7	2.7	2.7	2.7	2.7	2.7	2.7	2.7	
Max. torsional backlash	j_t	arcmin	Standard ≤ 4 / Reduced ≤ 2														
Torsional rigidity	C_{t21}	Nm/ arcmin	91	87	111	119	111	119	111	119	123	127	95	115	125	112	
		in.lb/ arcmin	805	770	982	1053	982	1053	982	1053	1089	1124	841	1018	1106	991	
Tilting rigidity	C_{2K}	Nm/ arcmin	560														
		in.lb/ arcmin	4956														
Max. axial force ^{e)}	F_{2AMax}	N	6130														
		lb _f	1379														
Max. tilting moment	M_{2KMax}	Nm	1295														
		in.lb	11461														
Efficiency at full load	η	%	92														
Service life (For calculation, see the Chapter "Information")	L_h	h	> 20000														
Weight incl. standard adapter plate	<i>m</i>	kg	18,7														
		lb _m	41,3														
Operating noise (with $n_1=3000$ rpm no load)	L_{PA}	dB(A)	< 68														
Max. permitted housing temperature		°C	90														
		F	194														
Ambient temperature		°C	0 to +40														
		F	32 to 104														
Lubrication			Lubricated for life														
Paint			Blue RAL 5002														
Direction of rotation			Motor and gearhead opposite directions														
Protection class			IP 65														
Moment of inertia (relates to the drive) Clamping hub diameter [mm]	E 19	J_1	kgcm ²	1.01	0.76	0.88	0.85	0.76	0.75	0.70	0.69	0.70	0.69	0.69	0.69	0.69	0.69
			10 ³ in.lb.s ²	0.89	0.67	0.78	0.75	0.67	0.66	0.62	0.61	0.62	0.61	0.61	0.61	0.61	0.61
	G 24	J_1	kgcm ²	2.57	2.32	2.44	2.42	2.32	2.31	2.26	2.25	2.26	2.25	2.25	2.25	2.25	2.25
			10 ³ in.lb.s ²	2.27	2.05	2.16	2.14	2.05	2.04	2.00	1.99	2.00	1.99	1.99	1.99	1.99	1.99

Please contact us for information on the best configuration for S1 conditions of use (continuous operation).

^{a)} Other ratios available on request

^{b)} Higher speeds are possible if the nominal torque is reduced

^{c)} For higher ambient temperatures, please reduce input speed

^{d)} Idling torques decrease during operation

^{e)} Refers to center of the output shaft or flange

All technical data for front output side applies.

Technical data for rearward output versions, see page 386.

View A

3-stage:

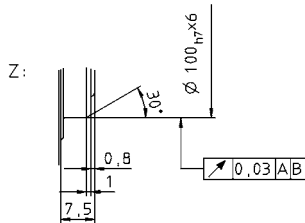
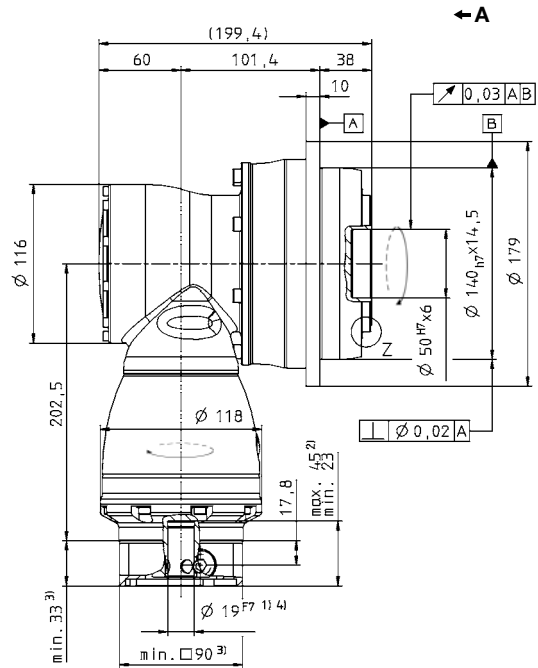
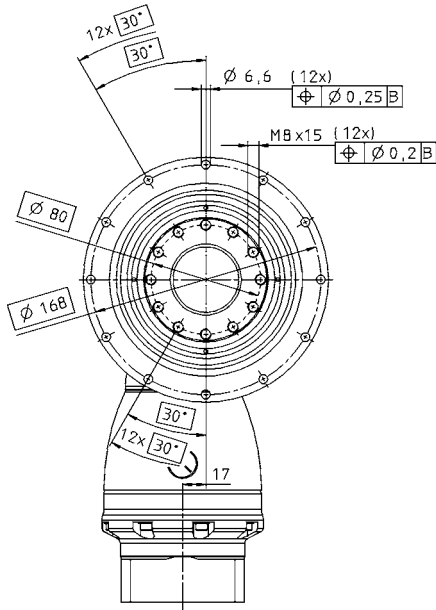

See technical data sheet for available clamping hub diameters (mass moment of inertia). Dimensions available on request.

Non-tolerated dimensions ± 1 mm

- 1) Check motor shaft fit.
- 2) Min./Max. permissible motor shaft length. Longer motor shafts are adaptable, please contact us.
- 3) The dimensions depend on the motor.
- 4) Smaller motor shaft diameter is compensated by a bushing with a minimum thickness of 1 mm.

CAD data is available under www.wittenstein-alpha.com

Motor mounting according to operating manual

TPK+ 110 MF 2-stage

		2-stage												
Ratio ^{a)}	<i>i</i>		12	16	20	25	28	35	40	49	50	70	100	
Max. acceleration torque (max. 1000 cycles per hour)	T_{2B}	Nm	1200	1200	1500	1500	1600	1600	840	1600	1050	1470	1400	
		in.lb	10620	10620	13275	13275	14160	14160	7434	14160	9293	13010	12390	
Nominal output torque (with n_m)	T_{2N}	Nm	700	700	750	750	750	750	640	750	750	750	750	
		in.lb	6195	6195	6638	6638	6638	6638	5664	6638	6638	6638	6638	
Emergency stop torque (permitted 1000 times during the service life of the gearhead)	T_{2Not}	Nm	1600	2000	2500	2500	2750	2750	1600	2750	2000	2750	2750	
		in.lb	14160	17700	22125	22125	24338	24338	14160	24338	17700	24338	24338	
Nominal input speed (with T_{2N} and 20 °C ambient temperature) ^{b), c)}	n_{1N}	rpm	1600	1900	1900	2100	1900	2100	2100	2100	2100	2100	2100	
Max. continuous speed (with 20% T_{2N} and 20 °C ambient temperature)	n_{1Ncym}	rpm	2300	2600	2600	2800	2600	3000	3000	3000	3000	3000	3000	
Max. input speed	n_{1Max}	rpm	4500	4500	4500	4500	4500	4500	4500	4500	4500	4500	4500	
Mean no load running torque (with $n_1=3000$ rpm and 20 °C gearhead temperature) ^{d)}	$T_{01/2}$	Nm	9.0	6.5	6.5	5.5	6.0	6.0	6.0	8.0	6.0	6.0	6.0	
		in.lb	79.7	57.5	57.5	48.7	53.1	53.1	53.1	70.8	53.1	53.1	53.1	
Max. torsional backlash	j_t	arcmin	Standard ≤ 4 / Reduced ≤ 2											
Torsional rigidity	C_{t21}	Nm/ arcmin	253	269	336	346	400	407	274	410	341	404	389	
		in.lb/ arcmin	2239	2381	2974	3062	3540	3602	2425	3629	3018	3575	3443	
Tilting rigidity	C_{2K}	Nm/ arcmin	1452											
		in.lb/ arcmin	12850											
Max. axial force ^{e)}	F_{2AMax}	N	10050											
		lb _f	2261											
Max. tilting moment	M_{2KMax}	Nm	3064											
		in.lb	27116											
Efficiency at full load	η	%	94											
Service life (For calculation, see the Chapter "Information")	L_h	h	> 20000											
Weight incl. standard adapter plate	<i>m</i>	kg	41.0											
		lb _m	91											
Operating noise (with $n_1 = 3000$ rpm no load)	L_{PA}	dB(A)	≤ 70											
Max. permitted housing temperature	°C		+90											
	F		194											
Ambient temperature	°C		0 to +40											
	F		32 to 104											
Lubrication	Lubricated for life													
Paint	Blue RAL 5002													
Direction of rotation	Motor and gearhead opposite directions													
Protection class	IP 65													
Moment of inertia (relates to the drive) Clamping hub diameter [mm]	K	38	J_1	kgcm ²	24.3	19.0	18.7	16.1	18.5	15.7	12.8	17.5	12.7	12.7
				10 ⁻⁴ in.lb.s ²	21.5	16.8	16.6	14.2	16.4	12.3	11.3	15.5	11.3	11.2

Please contact us for information on the best configuration for S1 conditions of use (continuous operation).

^{a)} Other ratios up to $i=1000$ available on request

^{b)} Higher speeds are possible if the nominal torque is reduced

^{c)} For higher ambient temperatures, please reduce input speed

^{d)} Idling torques decrease during operation

^{e)} Refers to center of the output shaft or flange

All technical data for front output side applies.

Technical data for rearward output versions, see page 386.

View A

2-stage:

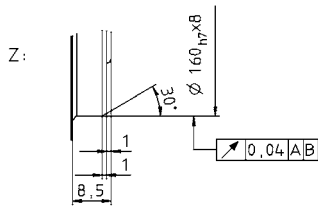
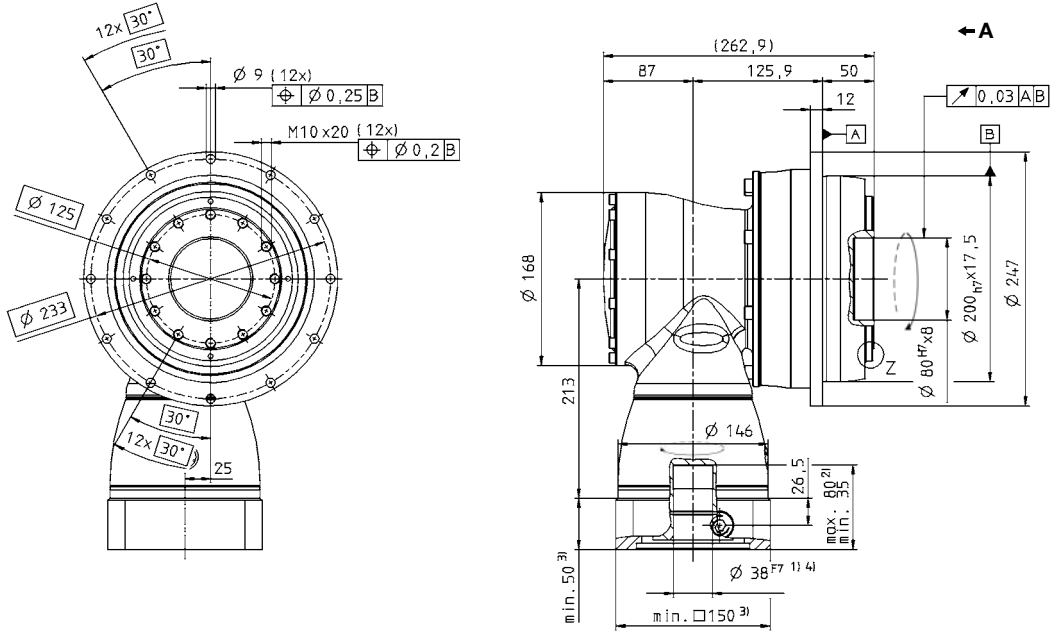

Right-angle gearheads
High End

TPK+

MF

See technical data sheet for available clamping hub diameters (mass moment of inertia). Dimensions available on request.

Non-tolerated dimensions ± 1 mm

- 1) Check motor shaft fit.
- 2) Min./Max. permissible motor shaft length. Longer motor shafts are adaptable, please contact us.
- 3) The dimensions depend on the motor.
- 4) Smaller motor shaft diameter is compensated by a bushing with a minimum thickness of 1 mm.

CAD data is available under www.wittenstein-alpha.com

Motor mounting according to operating manual

TPK+ 110 MF 3-stage

		3-stage															
Ratio ^{a)}		<i>i</i>	64	84	100	125	140	175	200	250	280	350	400	500	700	1000	
Max. acceleration torque (max. 1000 cycles per hour)	T_{2B}	Nm	1200	1200	1500	1500	1500	1500	1500	1500	1600	1600	840	1050	1470	1400	
		in.lb	10620	10620	13275	13275	13275	13275	13275	13275	14160	14160	7434	9293	13010	12390	
Nominal output torque (with n_m)	T_{2N}	Nm	700	700	950	950	950	950	950	950	1120	1250	640	750	1120	800	
		in.lb	6195	6195	8408	8408	8408	8408	8408	8408	9912	11063	5664	6638	9912	7080	
Emergency stop torque (permitted 1000 times during the service life of the gearhead)	T_{2Not}	Nm	1600	1600	2500	2500	2500	2500	2500	2500	2750	2750	1600	2000	2750	2750	
		in.lb	14160	14160	22125	22125	22125	22125	22125	22125	24338	24338	14160	17700	24338	24338	
Nominal input speed (with T_{2N} and 20 °C ambient temperature) ^{b), c)}	n_{1N}	rpm	2900	2900	2900	2900	2900	2900	2900	3200	2900	3200	3900	3900	3900	3900	
Max. continuous speed (with 20% T_{2N} and 20 °C ambient temperature)	n_{1Nsym}	rpm	4000	4000	4000	4000	4000	4000	4000	4000	4000	4000	4200	4200	4200	4200	
Max. input speed	n_{1Max}	rpm	4500	4500	4500	4500	4500	4500	4500	4500	4500	4500	4500	4500	4500	4500	
Mean no load running torque (with $n_1=3000$ rpm and 20 °C gearhead temperature) ^{d)}	$T_{01/2}$	Nm	1	0.5	0.8	0.6	0.6	0.5	0.5	0.4	0.5	0.4	0.4	0.4	0.4	0.4	
		in.lb	8.9	4.4	7.1	5.3	5.3	4.4	4.4	3.5	4.4	3.5	3.5	3.5	3.5	3.5	
Max. torsional backlash	j_t	arcmin	Standard ≤ 4 / Reduced ≤ 2														
Torsional rigidity	C_{t21}	Nm/ arcmin	269	252	336	346	336	346	336	346	400	407	274	341	404	389	
		in.lb/ arcmin	2381	2230	2974	3062	2974	3062	2974	3062	3540	3602	2425	3018	3575	3443	
Tilting rigidity	C_{2K}	Nm/ arcmin	1452														
		in.lb/ arcmin	12850														
Max. axial force ^{e)}	F_{2AMax}	N	10050														
		lb _f	2261														
Max. tilting moment	M_{2KMax}	Nm	3064														
		in.lb	27116														
Efficiency at full load	η	%	92														
Service life (For calculation, see the Chapter "Information")	L_h	h	> 20000														
Weight incl. standard adapter plate	<i>m</i>	kg	45,4														
		lb _m	100,3														
Operating noise (with $n_1=3000$ rpm no load)	L_{PA}	dB(A)	< 70														
Max. permitted housing temperature		°C	90														
		F	194														
Ambient temperature		°C	0 to +40														
		F	32 to 104														
Lubrication			Lubricated for life														
Paint			Blue RAL 5002														
Direction of rotation			Motor and gearhead opposite directions														
Protection class			IP 65														
Moment of inertia (relates to the drive)	G	24	J_1	kgcm ²	3.97	2.82	3.36	3.22	2.82	2.75	2.50	2.47	2.50	2.44	2.42	2.42	2.42
				10 ⁻³ in.lb.s ²	3.51	2.50	2.97	2.85	2.50	2.43	2.21	2.19	2.21	2.16	2.14	2.14	2.14
Clamping hub diameter [mm]	K	38	J_1	kgcm ²	10.90	9.74	10.30	10.10	9.74	9.66	9.41	9.38	9.41	9.38	9.33	9.33	9.33
				10 ⁻³ in.lb.s ²	9.65	8.62	9.12	8.94	8.62	8.55	8.33	8.30	8.33	8.30	8.26	8.26	8.26

Please contact us for information on the best configuration for S1 conditions of use (continuous operation).

^{a)} Other ratios available on request

^{b)} Higher speeds are possible if the nominal torque is reduced

^{c)} For higher ambient temperatures, please reduce input speed

^{d)} Idling torques decrease during operation

^{e)} Refers to center of the output shaft or flange

All technical data for front output side applies.

Technical data for rearward output versions, see page 386.

View A

3-stage:

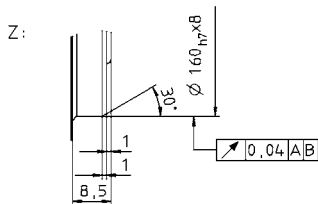
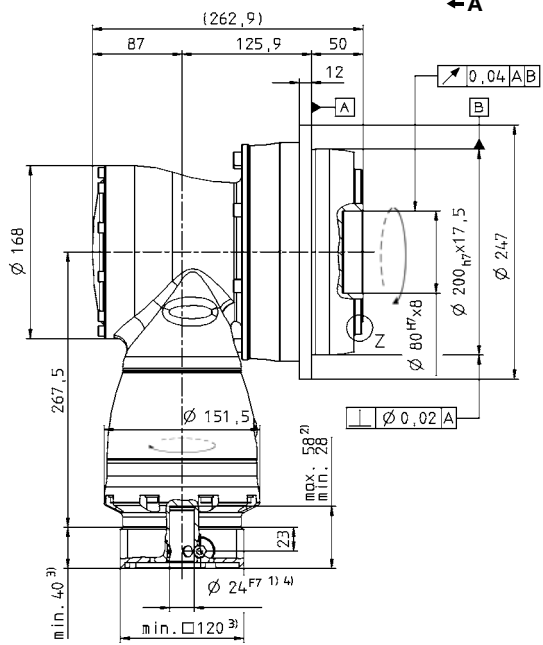
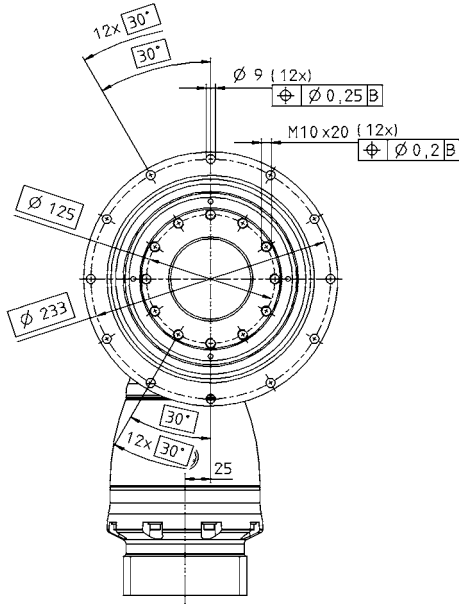

See technical data sheet for available clamping hub diameters (mass moment of inertia). Dimensions available on request.

Non-tolerated dimensions ± 1 mm

- 1) Check motor shaft fit.
- 2) Min./Max. permissible motor shaft length. Longer motor shafts are adaptable, please contact us.
- 3) The dimensions depend on the motor.
- 4) Smaller motor shaft diameter is compensated by a bushing with a minimum thickness of 1 mm.

CAD data is available under www.wittenstein-alpha.com

Motor mounting according to operating manual

TPK+ 300 MF 2-stage

		2-stage										
Ratio ^{a)}	<i>i</i>		15	20	25	35	49	50	70	100		
Max. acceleration torque (max. 1000 cycles per hour)	T_{2B}	Nm	3200	3200	3200	3300	3300	2350	3300	2800		
		in.lb	28320	28320	28320	29205	29205	20798	29205	24780		
Nominal output torque (with n_{in})	T_{2N}	Nm	2000	2000	2000	1800	1800	1800	1800	1600		
		in.lb	17.700	17.700	17.700	15.930	15.930	15.930	15.930	14.160		
Emergency stop torque (permitted 1000 times during the service life of the gearhead)	T_{2Not}	Nm	4500	5250	5250	7350	6800	4500	6300	8750		
		in.lb	39825	46463	46463	65048	60180	39825	55755	77438		
Nominal input speed (with T_{2N} and 20 °C ambient temperature) ^{b), c)}	n_{1N}	rpm	1500	1700	1900	1900	1700	1700	1700	1700		
Max. continuous speed (with 20% T_{2N} and 20 °C ambient temperature)	n_{1Nsym}	rpm	1900	2300	2700	2700	2400	2400	2400	2400		
Max. input speed	n_{1Max}	rpm	4000	4000	4000	4000	4000	4000	4000	4000		
Mean no load running torque (with $n_1=3000$ rpm and 20 °C gearhead temperature) ^{d)}	T_{012}	Nm	18.5	15.0	13.0	12.0	12.0	15.0	14.0	13.0		
		in.lb	163.7	132.8	115.1	106.2	106.2	132.8	123.9	115.1		
Max. torsional backlash	j_t	arcmin	Standard ≤ 4 / Reduced ≤ 2									
Torsional rigidity	C_{t21}	Nm/ arcmin	615	640	664	730	728	658	727	642		
		in.lb/ arcmin	5.443	5.664	5.876	6.461	6.443	5.823	6.434	5.682		
Tilting rigidity	C_{2K}	Nm/ arcmin	5560									
		in.lb/ arcmin	49206									
Max. axial force ^{e)}	F_{2AMax}	N	33000									
		lb _f	7425									
Max. tilting moment	M_{2KMax}	Nm	5900									
		in.lb	52215									
Efficiency at full load	η	%	94									
Service life (For calculation, see the Chapter "Information")	L_h	h	> 20000									
Weight incl. standard adapter plate	<i>m</i>	kg	83									
		lb _m	183									
Operating noise (with $n_1=3000$ rpm no load)	L_{PA}	dB(A)	≤ 71									
Max. permitted housing temperature		°C	+90									
		F	+194									
Ambient temperature		°C	0 to +40									
		F	32 to 104									
Lubrication			Lubricated for life									
Paint			Blue RAL 5002									
Direction of rotation			Motor and gearhead opposite directions									
Protection class			IP 65									
Moment of inertia (relates to the drive) Clamping hub diameter [mm]	M	48	J_1	kgcm ²	74.00	52.00	43.00	43.00	35.00	30.00	30.00	30.00
				10 ³ in.lb.in ²	65.49	46.02	38.06	38.06	30.98	26.55	26.55	26.55

Please contact us for information on the best configuration for S1 conditions of use (continuous operation).

^{a)} Other ratios available on request

^{b)} Higher speeds are possible if the nominal torque is reduced

^{c)} For higher ambient temperatures, please reduce input speed

^{d)} Idling torques decrease during operation

^{e)} Refers to center of the output shaft or flange

All technical data for front output side applies.

Technical data for rearward output versions, see page 386.

View A

2-stage:

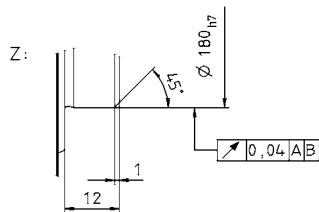
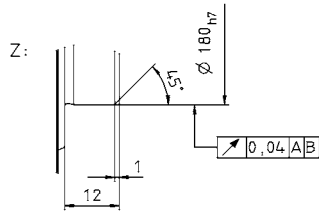
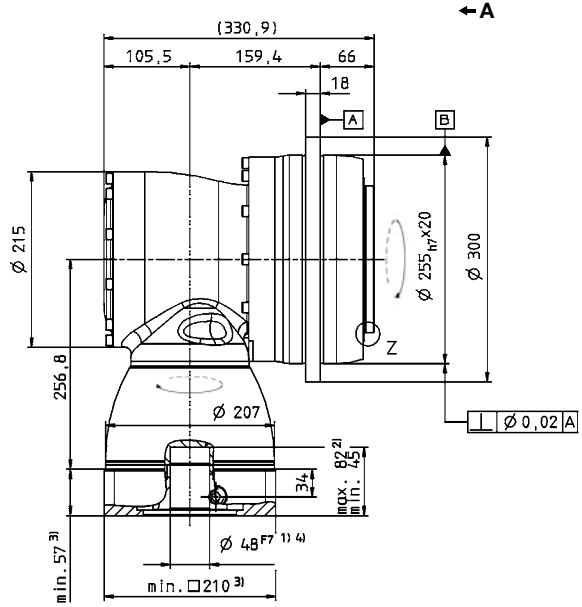
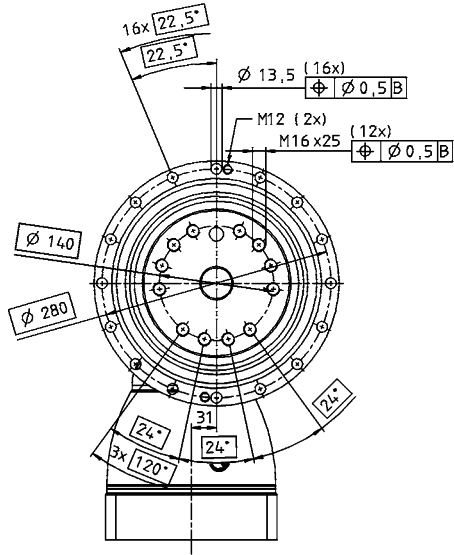

Right-angle gearheads
High End

TPK+

MF

See technical data sheet for available clamping hub diameters (mass moment of inertia). Dimensions available on request.

Non-tolerated dimensions ±1 mm

- 1) Check motor shaft fit.
- 2) Min./Max. permissible motor shaft length. Longer motor shafts are adaptable, please contact us.
- 3) The dimensions depend on the motor.
- 4) Smaller motor shaft diameter is compensated by a bushing with a minimum thickness of 1 mm.

CAD data is available under www.wittenstein-alpha.com

Motor mounting according to operating manual

TPK+ 300 MF 3-stage

		3-stage														
Ratio ^{a)}		<i>i</i>	63	100	125	140	175	200	250	280	350	500	700	1000		
Max. acceleration torque (max. 1000 cycles per hour)	T_{2B}	Nm	3300	3200	3200	3200	3200	3200	3200	3300	3300	2350	3300	2800		
		in.lb	29205	28320	28320	28320	28320	28320	28320	29205	29205	20798	29205	24780		
Nominal output torque (with n_m)	T_{2N}	Nm	1800	2000	2000	2000	2000	2000	2000	1800	1800	1800	1800	1600		
		in.lb	15.930	17.700	17.700	17.700	17.700	17.700	17.700	15.930	15.930	15.930	15.930	14.160		
Emergency stop torque (permitted 1000 times during the service life of the gearhead)	T_{2Not}	Nm	6300	5250	5250	5250	5250	5250	5250	7350	7350	4500	6300	8750		
		in.lb	55755	46463	46463	46463	46463	46463	46463	65048	65048	39825	55755	77438		
Nominal input speed (with T_{2N} and 20 °C ambient temperature) ^{b), c)}	n_{1N}	rpm	2700	2700	2700	2700	2700	2700	2900	2700	2900	3400	3400	3400		
Max. continuous speed (with 20% T_{2N} and 20 °C ambient temperature)	n_{1Ncym}	rpm	3200	3500	3500	3500	3500	3500	3500	3500	3500	3800	3800	3800		
Max. input speed	n_{1Max}	rpm	4000	4000	4000	4000	4000	4000	4000	4000	4000	4000	4000	4000		
Mean no load running torque (with $n_1=3000$ rpm and 20 °C gearhead temperature) ^{d)}	$T_{01/2}$	Nm	5.4	3.0	2.5	2.1	1.9	1.5	1.4	1.3	1.2	1.1	1.1	1.0		
		in.lb	47.8	26.6	22.1	18.6	16.8	13.3	12.4	0.0	10.6	9.7	9.7	8.9		
Max. torsional backlash	j_t	arcmin	Standard ≤ 4 / Reduced ≤ 2													
Torsional rigidity	C_{t21}	Nm/ arcmin	699	640	664	640	664	640	664	715	730	658	727	642		
		in.lb/ arcmin	6.186	5.664	5.876	5.664	5.876	5.664	5.876	6.328	6.461	5.823	6.434	5.682		
Tilting rigidity	C_{2K}	Nm/ arcmin	5560													
		in.lb/ arcmin	49210													
Max. axial force ^{e)}	F_{2AMax}	N	33000													
		lb _f	7425													
Max. tilting moment	M_{2KMax}	Nm	5900													
		in.lb	52215													
Efficiency at full load	η	%	92													
Service life (For calculation, see the Chapter "Information")	L_h	h	> 20000													
Weight incl. standard adapter plate	m	kg	87													
		lb _m	192													
Operating noise (with $n_1=3000$ rpm no load)	L_{PA}	dB(A)	≤ 71													
Max. permitted housing temperature		°C	+90													
		F	+194													
Ambient temperature		°C	0 to +40													
		F	32 to 104													
Lubrication			Lubricated for life													
Paint			Blue RAL 5002													
Direction of rotation			Motor and gearhead opposite directions													
Protection class			IP 65													
Moment of inertia (relates to the drive) Clamping hub diameter [mm]	K	38	J_1	kgcm ²	17.80	14.10	12.10	11.00	10.80	10.20	10.10	10.10	10.00	9.90	9.90	9.90
				10 ⁻³ in.lb.in ²	15.75	12.48	10.71	9.74	9.56	9.03	8.94	8.94	8.85	8.76	8.76	8.76
	M	48	J_1	kgcm ²	32.50	28.80	26.80	25.70	25.50	24.90	24.80	24.90	24.80	24.60	24.60	24.60
				10 ⁻³ in.lb.in ²	28.76	25.49	23.72	22.74	22.57	22.04	21.95	22.04	21.95	21.77	21.77	21.77

Please contact us for information on the best configuration for S1 conditions of use (continuous operation).

^{a)} Other ratios available on request

^{b)} Higher speeds are possible if the nominal torque is reduced

^{c)} For higher ambient temperatures, please reduce input speed

^{d)} Idling torques decrease during operation

^{e)} Refers to center of the output shaft or flange

All technical data for front output side applies.

Technical data for rearward output versions, see page 386.

View A

3-stage:

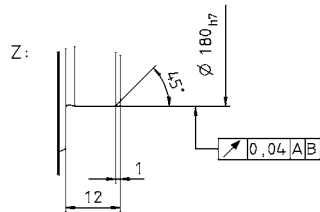
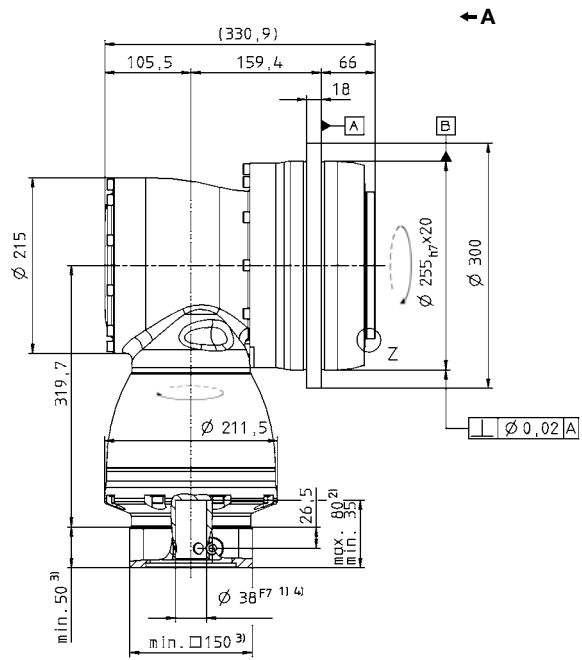
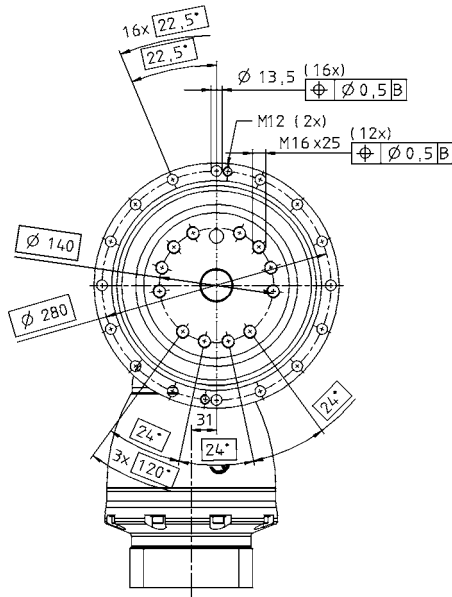

Right-angle gearheads
High End

TPK+

MF

See technical data sheet for available clamping hub diameters (mass moment of inertia). Dimensions available on request.

Non-tolerated dimensions ± 1 mm

- 1) Check motor shaft fit.
- 2) Min./Max. permissible motor shaft length. Longer motor shafts are adaptable, please contact us.
- 3) The dimensions depend on the motor.
- 4) Smaller motor shaft diameter is compensated by a bushing with a minimum thickness of 1 mm.

CAD data is available under www.wittenstein-alpha.com

Motor mounting according to operating manual

TPK+ 500 MF 3-stage

		3-stage												
Ratio ^{a)}	<i>i</i>	100	125	140	175	200	250	350	500	700	1000			
Max. acceleration torque (max. 1000 cycles per hour)	T_{2B}	Nm	6000	6000	5000	6000	4200	5250	6000	4500	5000	4800		
		in.lb	53100	53100	44250	53100	37170	46463	53100	39825	44250	42480		
Nominal output torque (with n_{in})	T_{2N}	Nm	3350	3800	3350	3800	3350	3800	3800	2900	2800	2900		
		in.lb	29648	33630	29648	33630	29648	33630	33630	25665	24780	25665		
Emergency stop torque (permitted 1000 times during the service life of the gearhead)	T_{2Not}	Nm	10000	12500	9000	11250	8000	10000	14000	15000	15000	15000		
		in.lb	88500	110625	79650	99563	70800	88500	123900	132750	132750	132750		
Nominal input speed (with T_{2N} and 20 °C ambient temperature) ^{b), c)}	n_{1N}	rpm	2100	2100	1900	1900	1900	1900	1900	1900	1900			
Max. continuous speed (with 20% T_{2N} and 20 °C ambient temperature)	n_{1Nsym}	rpm	2900	2900	2600	2600	2600	2600	2600	2600	2600			
Max. input speed	n_{1Max}	rpm	4500	4500	4500	4500	4500	4500	4500	4500	4500			
Mean no load running torque (with $n_1=3000$ rpm and 20 °C gearhead temperature) ^{d)}	$T_{01/2}$	Nm	5.5	5.5	8.5	8.5	6.0	6.0	6.0	6.0	6.0	6.0		
		in.lb	48.7	48.7	75.2	75.2	53.1	53.1	53.1	53.1	53.1	53.1		
Max. torsional backlash	j_t	arcmin	Standard $\leq 3,3$ / Reduced $\leq 2,3$											
Torsional rigidity	C_{t21}	Nm/ arcmin	1250	1350	1250	1350	1250	1350	1350	1280	1240	1050		
		in.lb/ arcmin	11063	11948	11063	11948	11063	11948	11948	11328	10974	9293		
Tilting rigidity	C_{2K}	Nm/ arcmin	9480											
		in.lb/ arcmin	83898											
Max. axial force ^{e)}	F_{2AMax}	N	50000											
		lb _f	11250											
Max. tilting moment	M_{2KMax}	Nm	8800											
		in.lb	77880											
Efficiency at full load	η	%	92											
Service life (For calculation, see the Chapter "Information")	L_h	h	> 20000											
Weight incl. standard adapter plate	<i>m</i>	kg	96											
		lb _m	212											
Operating noise (with $n_1=3000$ rpm no load)	L_{PA}	dB(A)	≤ 71											
Max. permitted housing temperature		°C	+90											
		F	+194											
Ambient temperature		°C	0 to +40											
		F	32 to 104											
Lubrication			Lubricated for life											
Paint			Blue RAL 5002											
Direction of rotation			Motor and gearhead opposite directions											
Protection class			IP 65											
Moment of inertia (relates to the drive) Clamping hub diameter [mm]	K	38	J_1	kgcm ²	16.70	16.70	16.50	16.50	16.40	16.40	16.40	16.40	16.40	16.40
				10 ³ in.lb.in ²	14.78	14.78	14.60	14.60	14.51	14.51	14.51	14.51	14.51	14.51

Please contact us for information on the best configuration for S1 conditions of use (continuous operation).

- ^{a)} Other ratios available on request
- ^{b)} Higher speeds are possible if the nominal torque is reduced
- ^{c)} For higher ambient temperatures, please reduce input speed
- ^{d)} Idling torques decrease during operation
- ^{e)} Refers to center of the output shaft or flange

All technical data for front output side applies.
Technical data for rearward output versions, see page 386.

View A

3-stage:

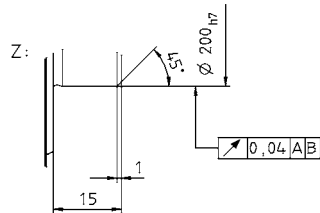
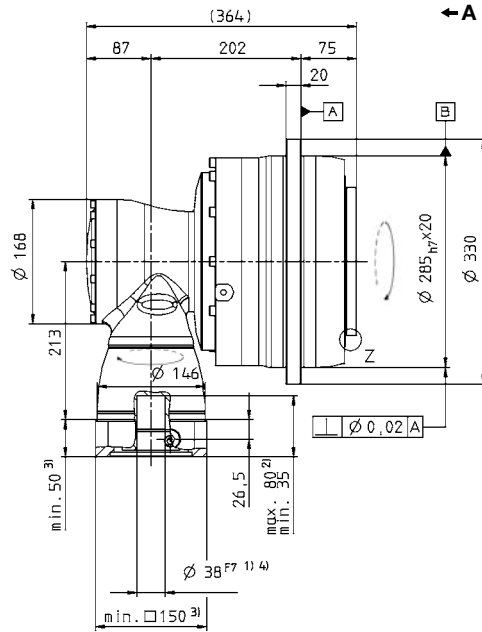
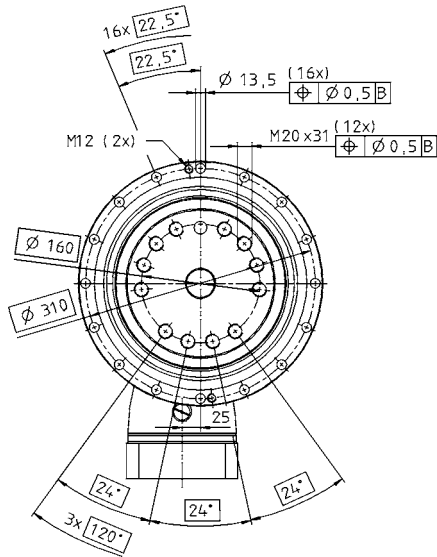

See technical data sheet for available clamping hub diameters (mass moment of inertia). Dimensions available on request.

Non-tolerated dimensions ± 1 mm

- 1) Check motor shaft fit.
- 2) Min./Max. permissible motor shaft length. Longer motor shafts are adaptable, please contact us.
- 3) The dimensions depend on the motor.
- 4) Smaller motor shaft diameter is compensated by a bushing with a minimum thickness of 1 mm.

CAD data is available under www.wittenstein-alpha.com

Motor mounting according to operating manual

TPK+ 500 MF 4-stage i=180-1000

		4-stage														
Ratio ^{a)}		<i>i</i>	180	240	300	375	420	500	560	600	700	800	875	1000		
Max. acceleration torque (max. 1000 cycles per hour)	T_{2B}	Nm	6000	6000	6000	6000	6000	6000	6000	6000	6000	6000	6000	6000		
		in.lb	53100	53100	53100	53100	53100	53100	53100	53100	53100	53100	53100	53100		
Nominal output torque (with n_{in})	T_{2N}	Nm	3350	3350	3350	3800	3350	3350	3350	3350	3350	3350	3800	3350		
		in.lb	29648	29648	29648	33630	29648	29648	29648	29648	29648	29648	33630	29648		
Emergency stop torque (permitted 1000 times during the service life of the gearhead)	T_{2Not}	Nm	10000	10000	10000	12500	10000	10000	10000	10000	10000	10000	12500	10000		
		in.lb	88500	88500	88500	110625	88500	88500	88500	88500	88500	88500	110625	88500		
Nominal input speed (with T_{2N} and 20 °C ambient temperature) ^{b), c)}	n_{1N}	rpm	2700	2900	2900	2900	2900	2900	2900	2900	2900	2900	2900	3200		
Max. continuous speed (with 20% T_{2N} and 20 °C ambient temperature)	n_{1Ncym}	rpm	3800	4000	4000	4000	4000	4000	4000	4000	4000	4000	4000	4200		
Max. input speed	n_{1Max}	rpm	4500	4500	4500	4500	4500	4500	4500	4500	4500	4500	4500	4500		
Mean no load running torque (with $n_1=3000$ rpm and 20 °C gearhead temperature) ^{d)}	$T_{01/2}$	Nm	3.4	2.5	1.6	1.4	1.1	1	1	0.8	0.8	0.7	0.7	0.6		
		in.lb	30.1	22.1	14.2	12.4	9.7	8.9	8.9	7.1	7.1	6.2	6.2	5.3		
Max. torsional backlash	j_t	arcmin	Standard $\leq 3,3$ / Reduced $\leq 2,3$													
Torsional rigidity	C_{t21}	Nm/ arcmin	1250	1250	1250	1300	1250	1350	1250	1250	1262	1250	1350	1250		
		in.lb/ arcmin	11063	11063	11063	11505	11063	11948	11063	11063	11169	11063	11948	11063		
Tilting rigidity	C_{2K}	Nm/ arcmin	9480													
		in.lb/ arcmin	83906													
Max. axial force ^{e)}	F_{2AMax}	N	50000													
		lb _f	11250													
Max. tilting moment	M_{2KMax}	Nm	8800													
		in.lb	77880													
Efficiency at full load	η	%	90													
Service life (For calculation, see the Chapter "Information")	L_h	h	> 20000													
Weight incl. standard adapter plate	m	kg	99													
		lb _m	219													
Operating noise (with $n_1=3000$ rpm no load)	L_{PA}	dB(A)	≤ 71													
Max. permitted housing temperature		°C	+90													
		F	+194													
Ambient temperature		°C	0 to +40													
		F	32 to 104													
Lubrication			Lubricated for life													
Paint			Blue RAL 5002													
Direction of rotation			Motor and gearhead opposite directions													
Protection class			IP 65													
Moment of inertia (relates to the drive) Clamping hub diameter [mm]	G	24	J_1	kgcm ²	5.93	4.29	3.33	3.32	2.81	3.19	2.80	2.50	2.74	2.49	2.74	2.46
				10 ⁻³ in.lb.s ²	5.25	3.79	2.95	2.94	2.49	2.82	2.48	2.21	2.42	2.20	2.42	2.18
	K	38	J_1	kgcm ²	12.84	11.18	10.24	10.23	9.72	10.10	9.71	9.41	9.65	9.40	9.65	9.37
				10 ⁻³ in.lb.s ²	11.37	9.89	9.06	9.06	8.60	8.94	8.59	8.33	8.54	8.32	8.54	8.29

Please contact us for information on the best configuration for S1 conditions of use (continuous operation).

^{a)} Other ratios available on request

^{b)} Higher speeds are possible if the nominal torque is reduced

^{c)} For higher ambient temperatures, please reduce input speed

^{d)} Idling torques decrease during operation

^{e)} Refers to center of the output shaft or flange

All technical data for front output side applies.

Technical data for rearward output versions, see page 386.

View A

4-stage:

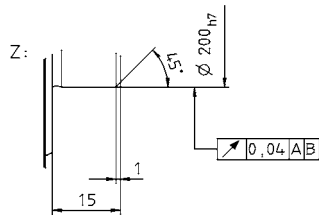
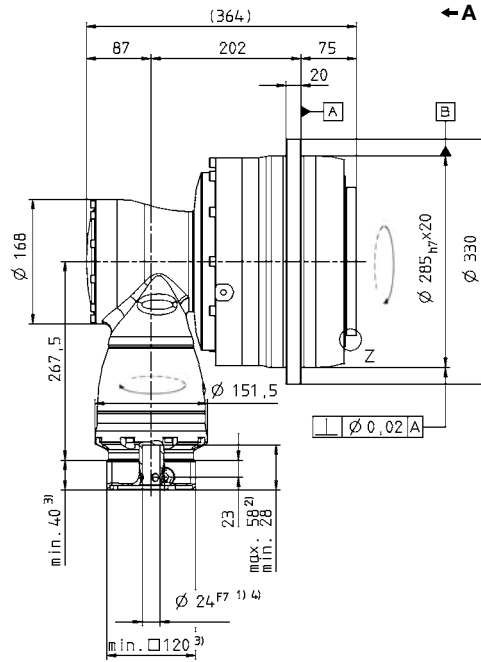
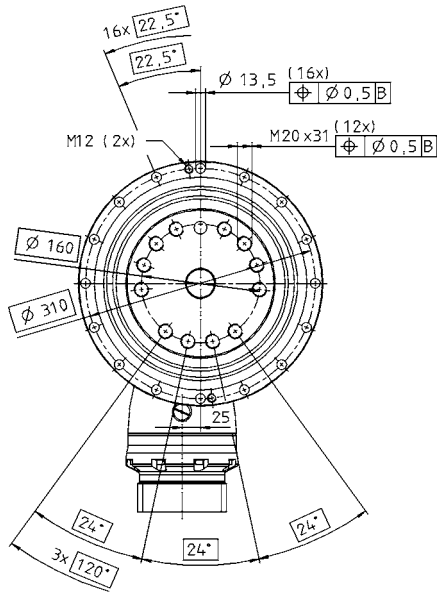

Right-angle gearheads
High End

TPK+

MF

See technical data sheet for available clamping hub diameters (mass moment of inertia). Dimensions available on request.

Non-tolerated dimensions ± 1 mm

- 1) Check motor shaft fit.
- 2) Min./Max. permissible motor shaft length. Longer motor shafts are adaptable, please contact us.
- 3) The dimensions depend on the motor.
- 4) Smaller motor shaft diameter is compensated by a bushing with a minimum thickness of 1 mm.

CAD data is available under www.wittenstein-alpha.com

Motor mounting according to operating manual

TPK+ 500 MF 4-stage i=1225-10000

		4-stage											
Ratio ^{a)}		<i>i</i>	1225	1400	1750	2000	2800	3500	5000	7000	10000		
Max. acceleration torque (max. 1000 cycles per hour)	T_{2B}	Nm	6000	6000	6000	4200	5000	6000	4500	5000	4800		
		in.lb	53100	53100	53100	37170	44250	53100	39825	44250	42480		
Nominal output torque (with n_{2N})	T_{2N}	Nm	3800	3800	3800	3200	2800	3800	2900	2800	2900		
		in.lb	33630	33630	33630	28320	24780	33630	25665	24780	25665		
Emergency stop torque (permitted 1000 times during the service life of the gearhead)	T_{2Not}	Nm	15000	15000	15000	8000	11200	14000	15000	15000	15000		
		in.lb	132750	132750	132750	70800	99120	123900	132750	132750	132750		
Nominal input speed (with T_{2N} and 20 °C ambient temperature) ^{b), c)}	n_{1N}	rpm	2900	2900	3200	3900	3900	3900	3900	3900	3900		
Max. continuous speed (with 20% T_{2N} and 20 °C ambient temperature)	n_{1Ncym}	rpm	4000	4000	4200	4200	4200	4200	4200	4200	4200		
Max. input speed	n_{1Max}	rpm	4500	4500	4500	4500	4500	4500	4500	4500	4500		
Mean no load running torque (with $n_1=3000$ rpm and 20 °C gearhead temperature) ^{d)}	$T_{01/2}$	Nm	0.6	0.6	0.4	0.4	0.4	0.4	0.4	0.4	0.4		
		in.lb	5.3	5.3	3.5	3.5	3.5	3.5	3.5	3.5	3.5		
Max. torsional backlash	j_t	arcmin	Standard $\leq 3,3$ / Reduced $\leq 2,3$										
Torsional rigidity	C_{t21}	Nm/ arcmin	1350	1350	1350	1250	1250	1350	1250	1250	1050		
		in.lb/ arcmin	11948	11948	11948	11063	11063	11948	11063	11063	9293		
Tilting rigidity	C_{2K}	Nm/ arcmin	9480										
		in.lb/ arcmin	83906										
Max. axial force ^{e)}	F_{2AMax}	N	50000										
		lb _f	11250										
Max. tilting moment	M_{2KMax}	Nm	8800										
		in.lb	77880										
Efficiency at full load	η	%	90										
Service life (For calculation, see the Chapter "Information")	L_h	h	> 20000										
Weight incl. standard adapter plate	<i>m</i>	kg	99										
		lb _m	219										
Operating noise (with $n_1=3000$ rpm no load)	L_{PA}	dB(A)	≤ 71										
Max. permitted housing temperature		°C	+90										
		F	+194										
Ambient temperature		°C	0 to +40										
		F	32 to 104										
Lubrication			Lubricated for life										
Paint			Blue RAL 5002										
Direction of rotation			Motor and gearhead opposite directions										
Protection class			IP 65										
Moment of inertia (relates to the drive) Clamping hub diameter [mm]	G	24	J_1	kgcm ²	2.73	2.49	2.46	2.42	2.42	2.42	2.42	2.42	2.42
				10 ³ in.lb.s ²	2.42	2.20	2.17	2.14	2.14	2.14	2.14	2.14	2.14
	K	38	J_1	kgcm ²	9.64	9.40	9.37	9.33	9.33	9.33	9.33	9.33	9.33
				10 ³ in.lb.s ²	8.53	8.32	8.29	8.26	8.26	8.26	8.26	8.26	8.26

Please contact us for information on the best configuration for S1 conditions of use (continuous operation).

^{a)} Other ratios available on request

^{b)} Higher speeds are possible if the nominal torque is reduced

^{c)} For higher ambient temperatures, please reduce input speed

^{d)} Idling torques decrease during operation

^{e)} Refers to center of the output shaft or flange

All technical data for front output side applies.

Technical data for rearward output versions, see page 386.

View A

4-stage:

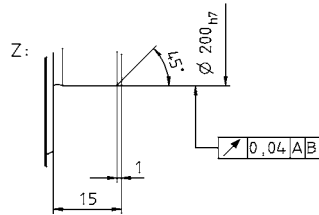
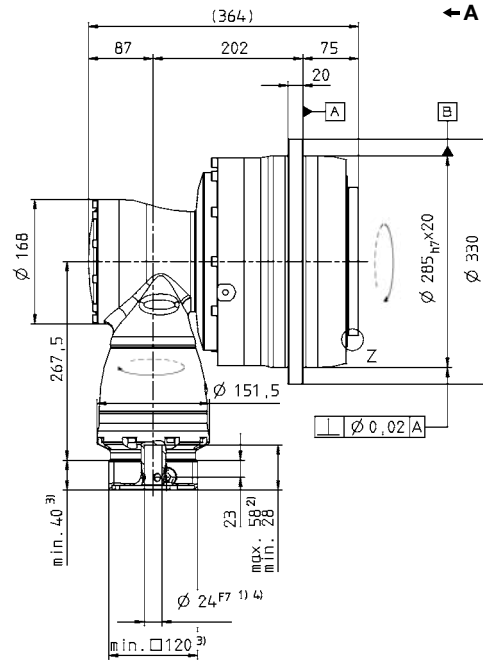
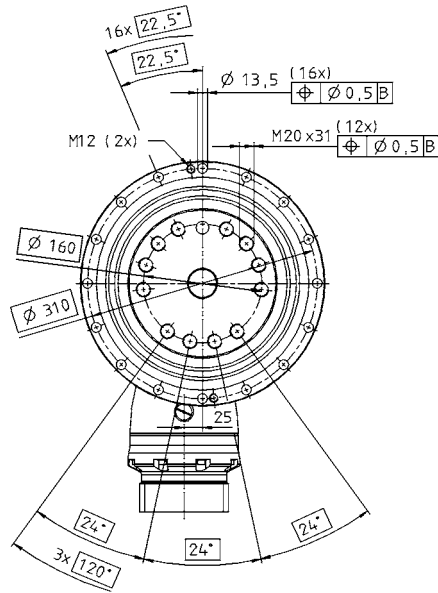

See technical data sheet for available clamping hub diameters (mass moment of inertia). Dimensions available on request.

Non-tolerated dimensions ± 1 mm

- 1) Check motor shaft fit.
- 2) Min./Max. permissible motor shaft length. Longer motor shafts are adaptable, please contact us.
- 3) The dimensions depend on the motor.
- 4) Smaller motor shaft diameter is compensated by a bushing with a minimum thickness of 1 mm.

CAD data is available under www.wittenstein-alpha.com

Motor mounting according to operating manual

TPK+ 025 MA HIGH TORQUE 3-/4-stage

				3-stage						4-stage										
Ratio ^{a)}		<i>i</i>	66	88	110	137.5	154	220	385	330	462	577.5	770	1078	1540	2695	3850	5500		
Max. acceleration torque (max. 1000 cycles per hour)	T_{2B}	Nm	530	530	530	530	530	440	530	530	530	530	530	530	530	530	530	530	530	
		in.lb	4691	4691	4691	4691	4691	3894	4691	4691	4691	4691	4691	4691	4691	4691	4691	4691	4691	4691
Nominal output torque (with n_m)	T_{2N}	Nm	375	375	375	375	375	330	375	375	375	375	375	375	375	375	375	375	375	375
		in.lb	3319	3319	3319	3319	3319	2921	3319	3319	3319	3319	3319	3319	3319	3319	3319	3319	3319	3319
Emergency stop torque (permitted 1000 times during the service life of the gearhead)	T_{2Not}	Nm	880	1100	1100	1100	990	880	1200	880	1200	1100	1200	1200	1200	1200	1200	1200	1200	1200
		in.lb	7788	9735	9735	9735	8762	7788	10620	7788	10620	9735	10620	10620	10620	10620	10620	10620	10620	10620
Nominal input speed (with T_{2N} and 20 °C ambient temperature) ^{b), c)}	n_{1N}	rpm	2400	2600	2900	2900	2900	2900	2900	4300	4300	4300	4300	4300	4300	5400	5400	5400	5400	
Max. continuous speed (with 20% T_{2N} and 20 °C ambient temperature)	n_{1Nsym}	rpm	2800	3300	3800	3800	3300	3300	3300	4800	4800	4800	4800	4800	4800	5400	5400	5400	5400	
Max. input speed	n_{1Max}	rpm	6000	6000	6000	6000	6000	6000	6000	6000	6000	6000	6000	6000	6000	6000	6000	6000	6000	
Mean no load running torque (with $n_1=3000$ rpm and 20 °C gearhead temperature) ^{d)}	$T_{01/2}$	Nm	1.6	1.4	1.2	1.2	1.4	1.2	1.2	0.3	0.3	0.2	0.2	0.2	0.1	0.1	0.1	0.1	0.1	
		in.lb	13.9	12.2	10.8	10.6	12.0	10.7	10.4	2.4	2.4	2.2	2.1	2.0	1.1	1.0	1.0	1.0	0.9	
Max. torsional backlash	j_t	arcmin	≤1.3																	
Torsional rigidity	C_{t21}	Nm/arcmin	95	95	96	99	95	94	101	95	101	98	98	102	102	101	101	98	98	
		in.lb/arcmin	838	842	846	874	838	829	894	838	897	869	872	899	899	897	894	869	869	
Tilting rigidity	C_{2K}	Nm/arcmin	550																	
		in.lb/arcmin	4868																	
Max. axial force ^{e)}	F_{2AMax}	N	4150																	
		lb _f	934																	
Max. tilting moment	M_{2KMax}	Nm	550																	
		in.lb	4868																	
Efficiency at full load	η	%	92						90											
Service life (For calculation, see the Chapter "Information")	L_h	h	> 20.000																	
Weight incl. standard adapter plate	<i>m</i>	kg	-																	
		lb _m	-																	
Operating noise (with $n_1=3000$ rpm no load)	L_{PA}	dB(A)	≤ 66																	
Max. permitted housing temperature		°C	90																	
		F	194																	
Ambient temperature		°C	0 to +40																	
		F	32 to 104																	
Lubrication			Lubricated for life																	
Paint			Blue RAL 5002																	
Direction of rotation			Motor and gearhead opposite directions																	
Protection class			IP 65																	
Moment of inertia (relates to the drive) Clamping hub diameter [mm]	B	11	J_1	kgcm ²	-	-	-	-	-	-	0.08	0.09	0.06	0.06	0.06	0.06	0.06	0.06	0.06	
				10 ⁻³ in.lb.s ²	-	-	-	-	-	-	0.07	0.08	0.06	0.06	0.06	0.05	0.05	0.05	0.05	0.05
	C	14	J_1	kgcm ²	0.56	0.46	0.41	0.40	0.37	0.35	0.34	0.19	0.20	0.18	0.18	0.18	0.17	0.17	0.17	
				10 ⁻³ in.lb.s ²	0.50	0.41	0.36	0.36	0.33	0.31	0.31	0.17	0.18	0.16	0.16	0.16	0.15	0.15	0.15	0.15
E	19	J_1	kgcm ²	0.91	0.81	0.76	0.76	0.72	0.70	0.70	-	-	-	-	-	-	-	-		
			10 ⁻³ in.lb.s ²	0.81	0.72	0.67	0.67	0.64	0.62	0.62	-	-	-	-	-	-	-	-	-	

Please contact us for information on the best configuration for S1 conditions of use (continuous operation).

- ^{a)} Other ratios available on request
- ^{b)} Higher speeds are possible if the nominal torque is reduced
- ^{c)} For higher ambient temperatures, please reduce input speed
- ^{d)} Idling torques decrease during operation
- ^{e)} Refers to center of the output shaft or flange

All technical data for front output side applies.

Technical data for rearward output versions, see page 386.

View A

3-stage:

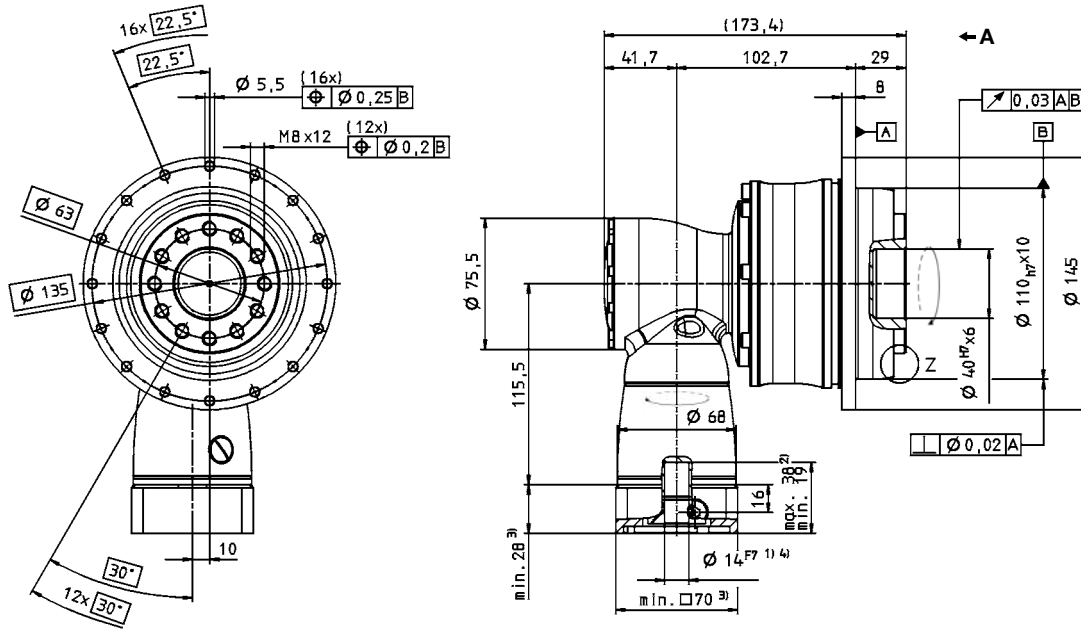

4-stage:

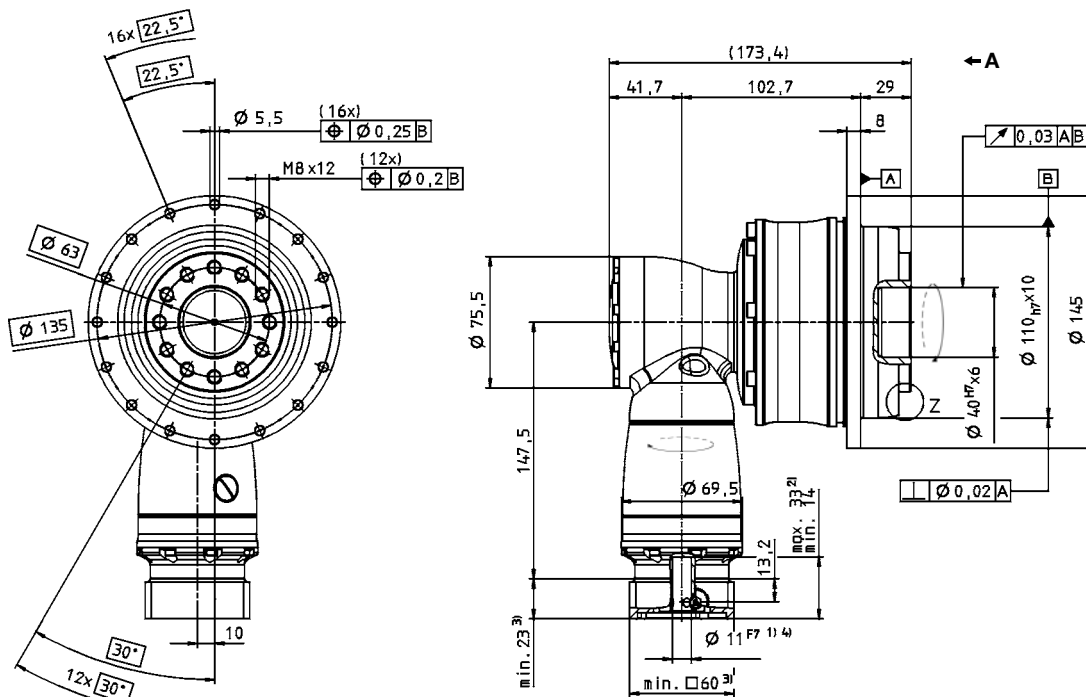

See technical data sheet for available clamping hub diameters (mass moment of inertia). Dimensions available on request.

Non-tolerated dimensions ±1 mm

- 1) Check motor shaft fit.
- 2) Min./Max. permissible motor shaft length. Longer motor shafts are adaptable, please contact us.
- 3) The dimensions depend on the motor.
- 4) Smaller motor shaft diameter is compensated by a bushing with a minimum thickness of 1 mm.

CAD data is available under www.wittenstein-alpha.com

Motor mounting according to operating manual

TPK+ 050 MA HIGH TORQUE 3/4-stage

		3-stage								4-stage										
Ratio ^{a)}	<i>i</i>	66	88	110	137,5	154	220	385	330	462	577,5	770	1078	1540	2695	3850	5500			
Max. acceleration torque (max. 1000 cycles per hour)	T_{2B}	Nm	950	950	950	950	950	950	950	950	950	950	950	950	950	950	950	950		
		in.lb	8408	8408	8408	8408	8408	8408	8408	8408	8408	8408	8408	8408	8408	8408	8408	8408		
Nominal output torque (with n_m)	T_{2N}	Nm	675	675	675	675	675	675	675	675	675	675	675	675	675	675	675	675		
		in.lb	5.974	5.974	5.974	5.974	5.974	5.974	5.974	5.974	5.974	5.974	5.974	5.974	5.974	5.974	5.974	5.974		
Emergency stop torque (permitted 1000 times during the service life of the gearhead)	T_{2Not}	Nm	2100	2375	2375	2375	2375	2200	2375	2100	2375	2375	2375	2375	2375	2375	2375	2375		
		in.lb	18585	21019	21019	21019	21019	19470	21019	18585	21019	21019	21019	21019	21019	21019	21019	21019		
Nominal input speed (with T_{2N} and 20 °C ambient temperature) ^{b), c)}	n_{1N}	rpm	2200	2400	2700	2700	2700	2700	2700	3400	3400	3400	3400	3400	4400	4400	4400			
Max. continuous speed (with 20% T_{2N} and 20 °C ambient temperature)	n_{1Ncym}	rpm	2800	3300	3800	3800	3300	3300	3300	4300	4300	4300	4300	4300	4400	4400	4400			
Max. input speed	n_{1Max}	rpm	6000	6000	6000	6000	6000	6000	6000	6000	6000	6000	6000	6000	6000	6000	6000			
Mean no load running torque (with $n_1=3000$ rpm and 20 °C gearhead temperature) ^{d)}	$T_{01/2}$	Nm	2.9	2.4	2.0	2.1	2.4	2.1	2.0	0.4	0.5	0.3	0.3	0.3	0.2	0.1	0.1	0.1		
		in.lb	25.7	21.0	18.1	18.4	21.1	18.3	17.7	3.4	4.1	3.0	2.7	2.4	1.3	1.1	1.1	1.0		
Max. torsional backlash	j_t	arcmin	≤ 1,3																	
Torsional rigidity	C_{t21}	Nm/ arcmin	202	203	205	210	205	205	215	202	214	208	209	214	214	215	215	217		
		in.lb/ arcmin	1785	1798	1810	1857	1810	1810	1900	1785	1891	1840	1849	1896	1900	1900	1924			
Tilting rigidity	C_{2K}	Nm/ arcmin	560																	
		in.lb/ arcmin	4956																	
Max. axial force ^{e)}	F_{2AMax}	N	6130																	
		lb _f	1379																	
Max. tilting moment	M_{2KMax}	Nm	1335																	
		in.lb	11815																	
Efficiency at full load	η	%	92								90									
Service life (For calculation, see the Chapter "Information")	L_h	h	> 20000																	
Weight incl. standard adapter plate	<i>m</i>	kg	-																	
		lb _m	-																	
Operating noise (with $n_1=3000$ rpm no load)	L_{PA}	dB(A)	≤ 68																	
Max. permitted housing temperature		°C	+90																	
		F	+194																	
Ambient temperature		°C	0 to +40																	
		F	32 to 104																	
Lubrication			Lubricated for life																	
Paint			Blue RAL 5002																	
Direction of rotation			Motor and gearhead opposite directions																	
Protection class			IP 65																	
Moment of inertia (relates to the drive) Clamping hub diameter [mm]	E	19	J_1	kgcm ²	-	-	-	-	-	-	0,24	0,29	0,20	0,20	0,20	0,19	0,18	0,18	0,18	
				10 ⁻³ in.lb.s ²	-	-	-	-	-	-	0,21	0,26	0,18	0,18	0,18	0,16	0,16	0,16	0,16	0,16
	G	24	J_1	kgcm ²	1,65	1,30	1,13	1,11	0,99	0,91	0,90	0,68	0,73	0,63	0,63	0,63	0,63	0,63	0,63	0,63
				10 ⁻³ in.lb.s ²	1,46	1,15	1,00	0,98	0,87	0,81	0,80	0,61	0,65	0,56	0,56	0,56	0,56	0,55	0,55	0,55
H	28	J_1	kgcm ²	3,07	2,71	2,54	2,53	2,40	2,33	2,32	-	-	-	-	-	-	-	-		
			10 ⁻³ in.lb.s ²	2,72	2,40	2,25	2,24	2,13	2,06	2,05	-	-	-	-	-	-	-	-		

Please contact us for information on the best configuration for S1 conditions of use (continuous operation).

- ^{a)} Other ratios available on request
- ^{b)} Higher speeds are possible if the nominal torque is reduced
- ^{c)} For higher ambient temperatures, please reduce input speed
- ^{d)} Idling torques decrease during operation
- ^{e)} Refers to center of the output shaft or flange

All technical data for front output side applies.
Technical data for rearward output versions, see page 386.

View A

3-stage:

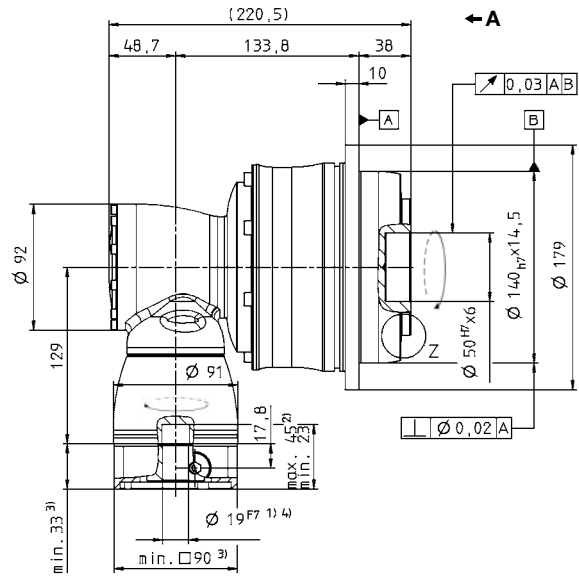
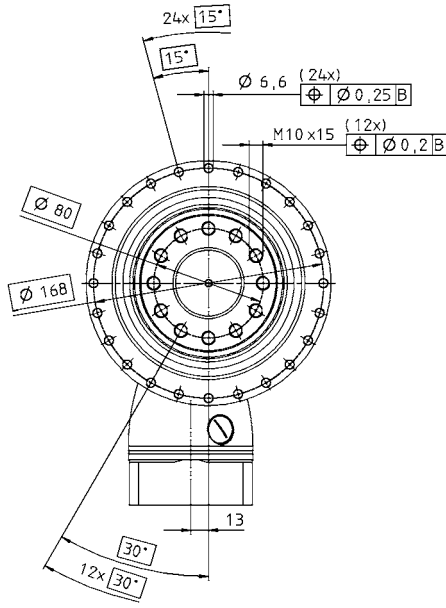

4-stage:

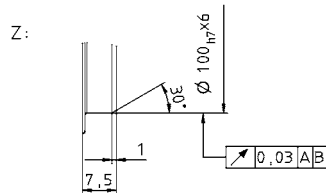
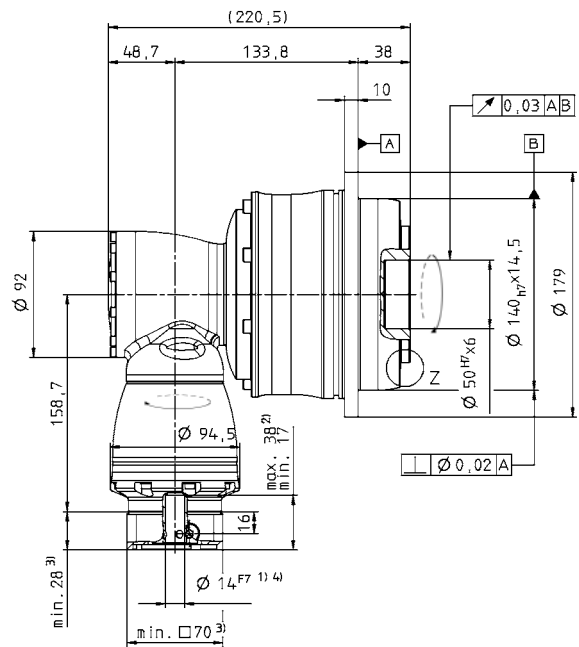
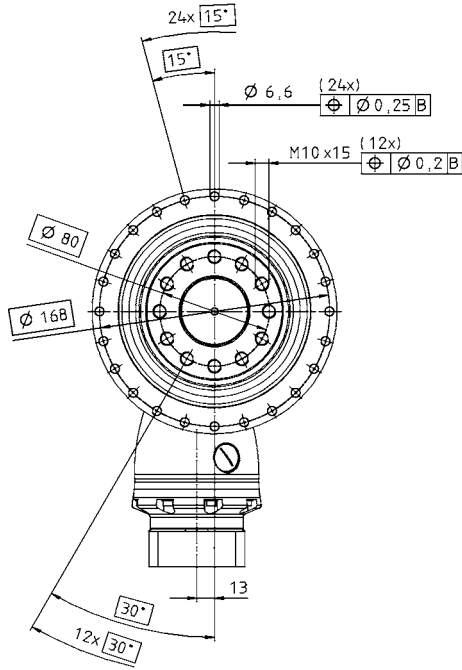

See technical data sheet for available clamping hub diameters (mass moment of inertia). Dimensions available on request.

Non-tolerated dimensions ±1 mm

- 1) Check motor shaft fit.
- 2) Min./Max. permissible motor shaft length. Longer motor shafts are adaptable, please contact us.
- 3) The dimensions depend on the motor.
- 4) Smaller motor shaft diameter is compensated by a bushing with a minimum thickness of 1 mm.

CAD data is available under www.wittenstein-alpha.com

Motor mounting according to operating manual

TPK+ 110 MA HIGH TORQUE 3/4-stage

		3-stage								4-stage									
Ratio ^{a)}	<i>i</i>	66	88	110	137,5	154	220	385	330	462	577,5	770	1078	1540	2695	3850	5500		
Max. acceleration torque (max. 1000 cycles per hour)	T_{2B}	Nm	3100	3100	3100	3100	3100	2750	3100	3100	3100	3100	3100	3100	3100	3100	3100	2000	
		in.lb	27435	27435	27435	27435	27435	24338	27435	27435	27435	27435	27435	27435	27435	27435	27435	17700	
Nominal output torque (with n_m)	T_{2N}	Nm	1650	1650	1650	1650	1650	1650	1650	1650	1650	1650	1650	1650	1650	1650	1650	1400	
		in.lb	14603	14603	14603	14603	14603	14603	14603	14603	14603	14603	14603	14603	14603	14603	14603	12390	
Emergency stop torque (permitted 1000 times during the service life of the gearhead)	T_{2Not}	Nm	4800	5700	5700	6500	5600	5500	6500	4800	6500	6000	6500	6500	6500	6500	6500	6500	
		in.lb	42480	50445	50445	57525	49560	48675	57525	42480	57525	53100	57525	57525	57525	57525	57525	57525	
Nominal input speed (with T_{2N} and 20 °C ambient temperature) ^{b), c)}	n_{1N}	rpm	2100	2300	2600	2600	2400	2400	2400	3000	3000	3000	3000	3000	3000	4100	4100	4100	
Max. continuous speed (with 20% T_{2N} and 20 °C ambient temperature)	n_{1Ncym}	rpm	2800	3200	3600	3600	3200	3200	3200	3800	3800	3800	3800	3800	3800	4100	4100	4100	
Max. input speed	n_{1Max}	rpm	4500	4500	4500	4500	4500	4500	4500	4500	4500	4500	4500	4500	4500	4500	4500	4500	
Mean no load running torque (with $n_1=3000$ rpm and 20 °C gearhead temperature) ^{d)}	$T_{01/2}$	Nm	6.0	4.6	3.6	3.4	4.4	3.5	3.3	0.9	1.0	0.7	0.6	0.6	0.3	0.3	0.2	0.2	
		in.lb	53.1	40.7	31.9	30.1	38.9	31.0	29.2	8.0	8.9	6.2	5.3	5.3	2.7	2.7	1.8	1.8	
Max. torsional backlash	j_t	arcmin	≤ 1,3																
Torsional rigidity	C_{t21}	Nm/ arcmin	634	642	654	675	654	648	687	634	682	662	667	685	685	689	687	658	
		in.lb/ arcmin	5614	5681	5789	5976	5789	5739	6083	5614	6037	5855	5902	6062	6062	6101	6083	5822	
Tilting rigidity	C_{2K}	Nm/ arcmin	1452																
		in.lb/ arcmin	12850																
Max. axial force ^{e)}	F_{2AMax}	N	10050																
		lb _f	2261																
Max. tilting moment	M_{2KMax}	Nm	3280																
		in.lb	29028																
Efficiency at full load	η	%	92								90								
Service life (For calculation, see the Chapter "Information")	L_h	h	> 20000																
Weight incl. standard adapter plate	<i>m</i>	kg	-																
		lb _m	-																
Operating noise (with $n_1=3000$ rpm no load)	L_{PA}	dB(A)	≤ 70																
Max. permitted housing temperature		°C	+90																
		F	+194																
Ambient temperature		°C	0 to +40																
		F	32 to 104																
Lubrication			Lubricated for life																
Paint			Blue RAL 5002																
Direction of rotation			Motor and gearhead opposite directions																
Protection class			IP 65																
Moment of inertia (relates to the drive) Clamping hub diameter [mm]	E	19	J_1	kgcm ²	-	-	-	-	-	-	0.89	1.06	0.76	0.76	0.76	0.69	0.68	0.68	0.68
				10 ³ in.lb.in ²	-	-	-	-	-	-	0.79	0.94	0.68	0.67	0.67	0.61	0.61	0.60	0.60
	G	24	J_1	kgcm ²	-	-	-	-	-	-	2.46	2.63	2.33	2.32	2.32	2.26	2.25	2.25	2.25
				10 ³ in.lb.in ²	-	-	-	-	-	-	2.17	2.33	2.06	2.06	2.05	2.00	1.99	1.99	1.99
	H	28	J_1	kgcm ²	5.48	4.27	3.64	3.58	3.14	2.87	2.84	-	-	-	-	-	-	-	-
				10 ³ in.lb.in ²	4.85	3.78	3.22	3.17	2.78	2.54	2.51	-	-	-	-	-	-	-	-
	K	38	J_1	kgcm ²	12.72	11.52	10.89	10.83	10.39	10.12	10.09	-	-	-	-	-	-	-	-
				10 ³ in.lb.in ²	11.26	10.19	9.64	9.58	9.19	8.95	8.93	-	-	-	-	-	-	-	-

Please contact us for information on the best configuration for S1 conditions of use (continuous operation).

^{a)} Other ratios available on request

^{b)} Higher speeds are possible if the nominal torque is reduced

^{c)} For higher ambient temperatures, please reduce input speed

^{d)} Idling torques decrease during operation

^{e)} Refers to center of the output shaft or flange

All technical data for front output side applies.

Technical data for rearward output versions, see page 386.

View A

3-stage:

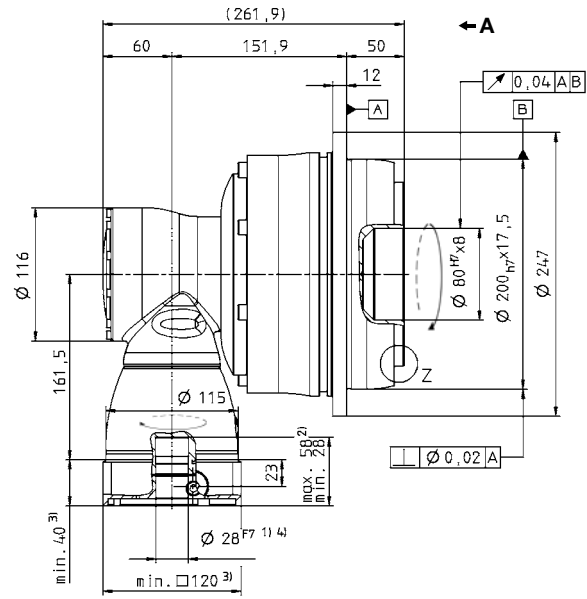
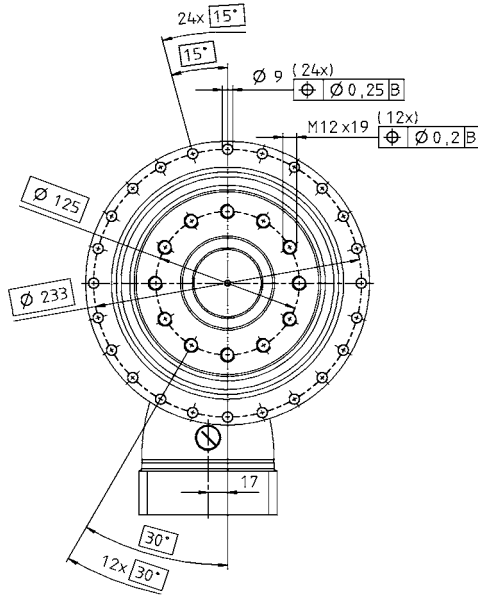

4-stage:

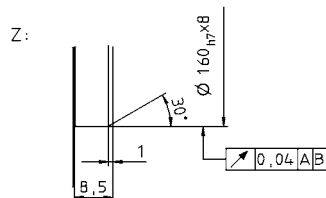
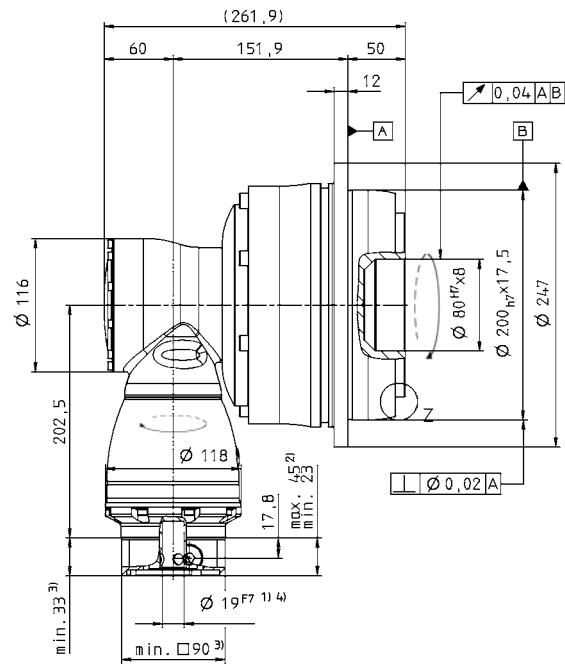
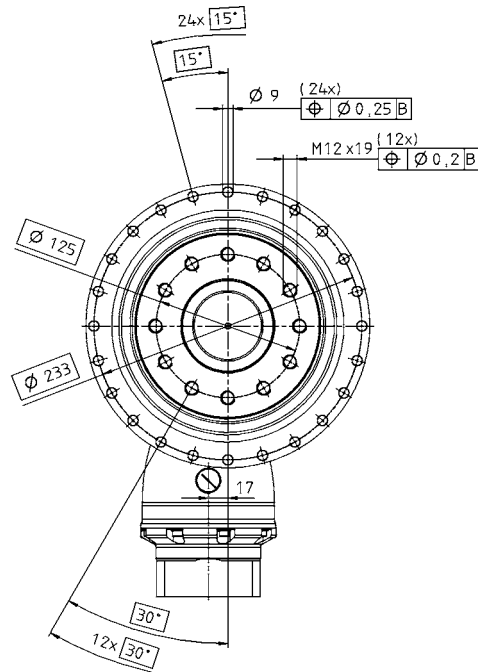

See technical data sheet for available clamping hub diameters (mass moment of inertia). Dimensions available on request.

Non-tolerated dimensions ± 1 mm

- 1) Check motor shaft fit.
- 2) Min./Max. permissible motor shaft length. Longer motor shafts are adaptable, please contact us.
- 3) The dimensions depend on the motor.
- 4) Smaller motor shaft diameter is compensated by a bushing with a minimum thickness of 1 mm.

CAD data is available under www.wittenstein-alpha.com

Motor mounting according to operating manual

TPK+ 300 MA HIGH TORQUE 3/4-stage

		3-stage							4-stage										
Ratio ^{a)}	<i>i</i>	66	88	110	137.5	154	220	385	330	462	577.5	770	1078	1540	2695	3850	5500		
Max. acceleration torque (max. 1000 cycles per hour)	T_{2B}	Nm	5500	5500	5500	5500	5500	4600	5500	5500	5500	5500	5500	5500	5500	5500	5500	3900	
		in.lb	48675	48675	48675	48675	48675	40710	48675	48675	48675	48675	48675	48675	48675	48675	48675	34515	
Nominal output torque (with n_m)	T_{2N}	Nm	3500	3500	3500	3500	3500	3500	3500	3500	3500	3500	3500	3500	3500	3500	3500	3500	
		in.lb	30975	30975	30975	30975	30975	30975	30975	30975	30975	30975	30975	30975	30975	30975	30975	30975	
Emergency stop torque (permitted 1000 times during the service life of the gearhead)	T_{2Not}	Nm	8800	11000	11000	11000	9900	8800	13250	8800	13250	11000	13250	13250	13250	13250	13250	13250	
		in.lb	77880	97350	97350	97350	87615	77880	117263	77880	117263	97350	117263	117263	117263	117263	117263	117263	
Nominal input speed (with T_{2N} and 20 °C ambient temperature) ^{b), c)}	n_{1N}	rpm	1800	1900	2100	2100	1900	1900	1900	2800	2800	2800	2800	2800	2800	3100	3800	3800	
Max. continuous speed (with 20% T_{2N} and 20 °C ambient temperature)	n_{1Ncym}	rpm	2300	2600	2900	2900	2600	2600	2600	3800	3800	3800	3800	3800	3800	4000	4000	4000	
Max. input speed	n_{1Max}	rpm	4500	4500	4500	4500	4500	4500	4500	4500	4500	4500	4500	4500	4500	4500	4500	4500	
Mean no load running torque (with $n_1=3000$ rpm and 20 °C gearhead temperature) ^{d)}	$T_{01/2}$	Nm	11.0	8.2	6.9	6.5	9.2	6.7	6.4	1.5	2.2	1.0	0.9	0.8	0.6	0.4	0.4	0.4	
		in.lb	97.4	72.6	61.1	57.5	81.4	59.3	56.6	13.3	19.5	8.9	8.0	7.1	5.3	3.5	3.5	3.5	
Max. torsional backlash	j_t	arcmin	Standard $\leq 3,3$ / Reduced $\leq 1,8$																
Torsional rigidity	C_{t21}	Nm/ arcmin	1099	1108	1114	960	1114	1111	979	1099	976	953	958	978	978	979	979	989	
		in.lb/ arcmin	9727	9809	9856	8499	9856	9834	8662	9727	8634	8437	8476	8655	8655	8667	8662	8757	
Tilting rigidity	C_{2K}	Nm/ arcmin	5560																
		in.lb/ arcmin	49210																
Max. axial force ^{e)}	F_{2AMax}	N	33000																
		lb _f	7425																
Max. tilting moment	M_{2KMax}	Nm	6500																
		in.lb	57525																
Efficiency at full load	η	%	92							90									
Service life (For calculation, see the Chapter "Information")	L_h	h	> 20000																
Weight incl. standard adapter plate	<i>m</i>	kg	83							87									
		lb _m	183							192									
Operating noise (with $n_1=3000$ rpm no load)	L_{PA}	dB(A)	≤ 71																
Max. permitted housing temperature		°C	+90																
		F	+194																
Ambient temperature		°C	0 to +40																
		F	32 to 104																
Lubrication			Lubricated for life																
Paint			Blue RAL 5002																
Direction of rotation			Motor and gearhead opposite directions																
Protection class			IP 65																
Moment of inertia (relates to the drive)	G 24	J_1	kgcm ²	-	-	-	-	-	-	-	3.32	4.24	2.80	2.79	2.79	2.49	2.43	2.42	2.42
			10 ³ in.lb.s ²	-	-	-	-	-	-	-	-	-	2.94	3.75	2.48	2.47	2.47	2.20	2.15
Clamping hub diameter [mm]	K 38	J_1	kgcm ²	26.04	19.71	16.71	16.58	14.26	12.89	12.83	10.23	11.15	9.71	9.70	9.70	9.40	9.34	9.33	9.33
			10 ³ in.lb.s ²	23.05	17.44	14.78	14.67	12.62	11.41	11.36	9.06	9.87	8.59	8.59	8.58	8.32	8.27	8.26	8.26

Please contact us for information on the best configuration for S1 conditions of use (continuous operation).

^{a)} Other ratios available on request

^{b)} Higher speeds are possible if the nominal torque is reduced

^{c)} For higher ambient temperatures, please reduce input speed

^{d)} Idling torques decrease during operation

^{e)} Refers to center of the output shaft or flange

All technical data for front output side applies.

Technical data for rearward output versions, see page 386.

View A

3-stage:

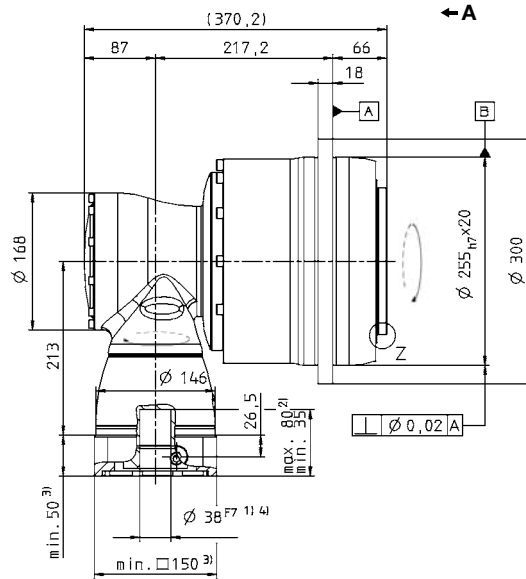
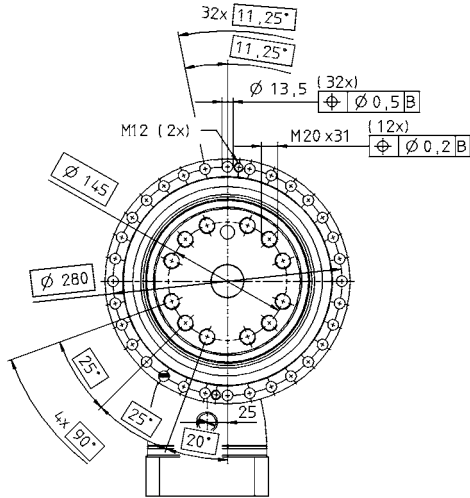

4-stage:

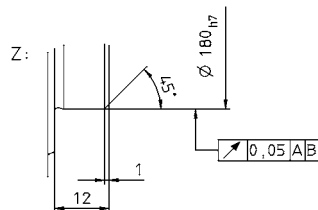
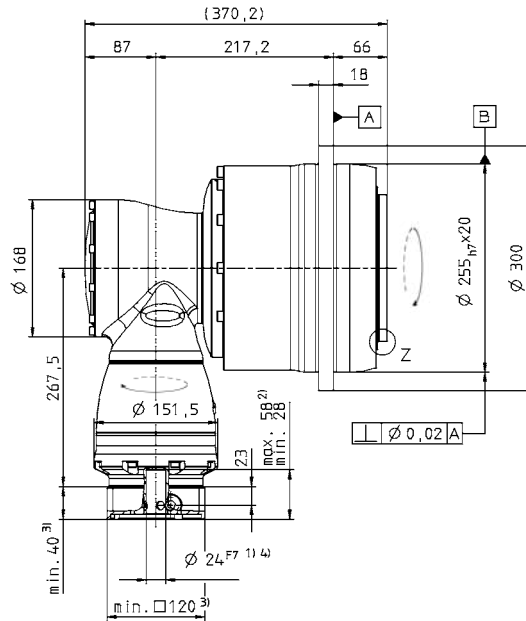
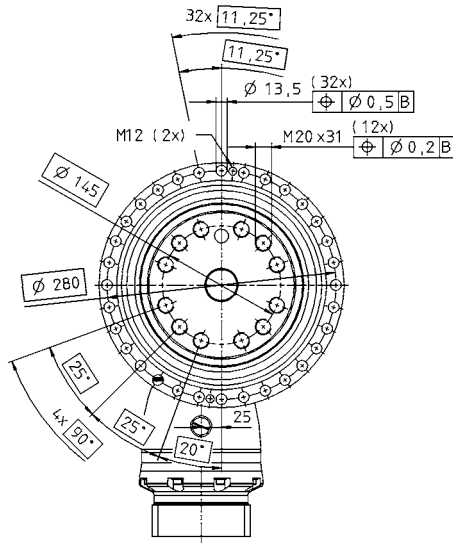

See technical data sheet for available clamping hub diameters (mass moment of inertia). Dimensions available on request.

Non-tolerated dimensions ± 1 mm

- 1) Check motor shaft fit.
- 2) Min./Max. permissible motor shaft length. Longer motor shafts are adaptable, please contact us.
- 3) The dimensions depend on the motor.
- 4) Smaller motor shaft diameter is compensated by a bushing with a minimum thickness of 1 mm.

CAD data is available under www.wittenstein-alpha.com

Motor mounting according to operating manual

TPK+ 500 MA HIGH TORQUE 3/4-stage

		3-stage								4-stage									
Ratio ^{a)}	<i>i</i>	66	88	110	137,5	154	220	385	330	462	577,5	770	1078	1540	2695	3850	5500		
Max. acceleration torque (max. 1000 cycles per hour)	T_{2B}	Nm	10000	10000	10000	10000	10000	10000	10000	10000	10000	10000	10000	10000	10000	10000	10000	7200	
		in.lb	88500	88500	88500	88500	88500	88500	88500	88500	88500	88500	88500	88500	88500	88500	88500	88500	63720
Nominal output torque (with n_m)	T_{2N}	Nm	5400	5400	5400	5400	5400	5400	5400	5400	5400	5400	5400	5400	5400	5400	5400	5400	
		in.lb	47790	47790	47790	47790	47790	47790	47790	47790	47790	47790	47790	47790	47790	47790	47790	47790	
Emergency stop torque (permitted 1000 times during the service life of the gearhead)	T_{2Not}	Nm	19800	23000	23000	25000	21300	19800	25000	19800	25000	25000	25000	25000	25000	25000	25000	25000	
		in.lb	175230	203550	203550	221250	188505	175230	221250	175230	221250	221250	221250	221250	221250	221250	221250	221250	
Nominal input speed (with T_{2N} and 20 °C ambient temperature) ^{b), c)}	n_{1N}	rpm	1500	1700	1900	1900	1700	1700	2600	2600	2600	2600	2600	2600	3100	3300	3300		
Max. continuous speed (with 20% T_{2N} and 20 °C ambient temperature)	n_{1Ncym}	rpm	1800	2200	2600	2600	2300	2300	3100	3300	3300	3300	3300	3300	3600	3600	3600		
Max. input speed	n_{1Max}	rpm	4000	4000	4000	4000	4000	4000	4000	4000	4000	4000	4000	4000	4000	4000	4000		
Mean no load running torque (with $n_1 = 3000$ rpm and 20 °C gearhead temperature) ^{d)}	$T_{0/2}$	Nm	20.5	16.5	13.6	12.8	17.6	14.3	13.7	3.0	4.0	2.0	1.8	1.7	1.2	1.1	1.0	1.0	
		in.lb	181.4	146.0	120.4	113.3	155.8	126.6	121.2	26.6	35.4	17.7	15.9	15.0	10.6	9.7	8.9	8.9	
Max. torsional backlash	j_t	arcmin	Standard $\leq 3,3$ / Reduced $\leq 1,8$																
Torsional rigidity	C_{t21}	Nm/ arcmin	1879	1890	1901	1747	1899	1898	1772	1879	1766	1735	1742	1770	1770	1772	1772	1786	
		in.lb/ arcmin	16626	16727	16820	15464	16809	16799	15683	16626	15633	15359	15413	15662	15662	15686	15683	15808	
Tilting rigidity	C_{2K}	Nm/ arcmin	9480																
		in.lb/ arcmin	83906																
Max. axial force ^{e)}	F_{2AMax}	N	50000																
		lb _f	11250																
Max. tilting moment	M_{2KMax}	Nm	9500																
		in.lb	84075																
Efficiency at full load	η	%	92								90								
Service life (For calculation, see the Chapter "Information")	L_h	h	> 20000																
Weight incl. standard adapter plate	<i>m</i>	kg	120								124								
		lb _m	265								274								
Operating noise (with $n_1 = 3000$ rpm no load)	L_{PA}	dB(A)	≤ 71																
Max. permitted housing temperature		°C	+90																
		F	+194																
Ambient temperature		°C	0 to +40																
		F	32 to 104																
Lubrication			Lubricated for life																
Paint			Blue RAL 5002																
Direction of rotation			Motor and gearhead opposite directions																
Protection class			IP 65																
Moment of inertia (relates to the drive)	K 38	J_1	kgcm ²	-	-	-	-	-	-	-	12.43	15.36	10.93	10.92	10.91	10.13	9.95	9.91	9.91
			10 ³ in.lb.in ²	-	-	-	-	-	-	-	-	11.00	13.59	9.67	9.66	9.66	8.96	8.81	8.77
Clamping hub diameter [mm]	M 48	J_1	kgcm ²	75.54	52.83	42.94	42.67	34.37	29.87	29.73	27.14	30.07	25.64	25.63	25.62	24.84	24.66	24.62	24.62
			10 ³ in.lb.in ²	66.85	46.76	38.01	37.76	30.41	26.43	26.31	24.02	26.61	22.69	22.68	22.68	21.98	21.83	21.79	21.79

Please contact us for information on the best configuration for S1 conditions of use (continuous operation).

^{a)} Other ratios available on request

^{b)} Higher speeds are possible if the nominal torque is reduced

^{c)} For higher ambient temperatures, please reduce input speed

^{d)} Idling torques decrease during operation

^{e)} Refers to center of the output shaft or flange

All technical data for front output side applies.

Technical data for rearward output versions, see page 386.

View A

3-stage:

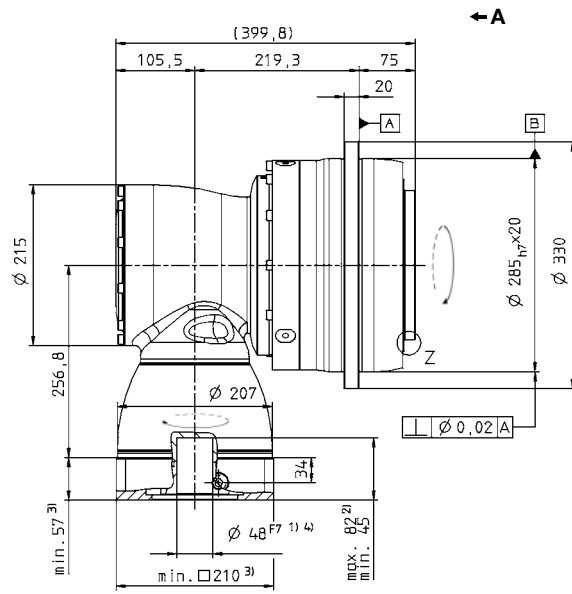
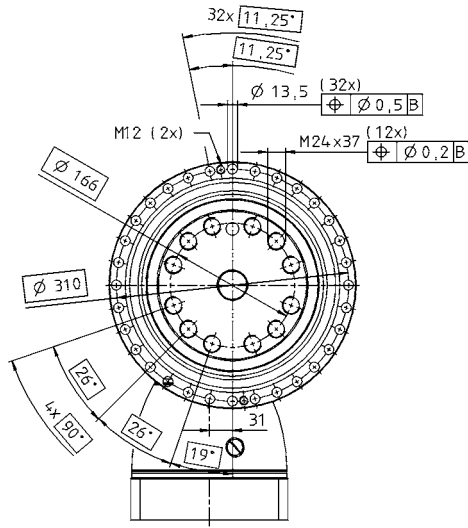

4-stage:

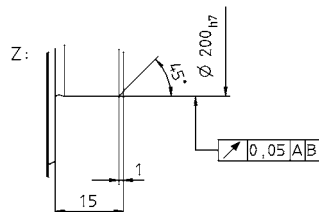
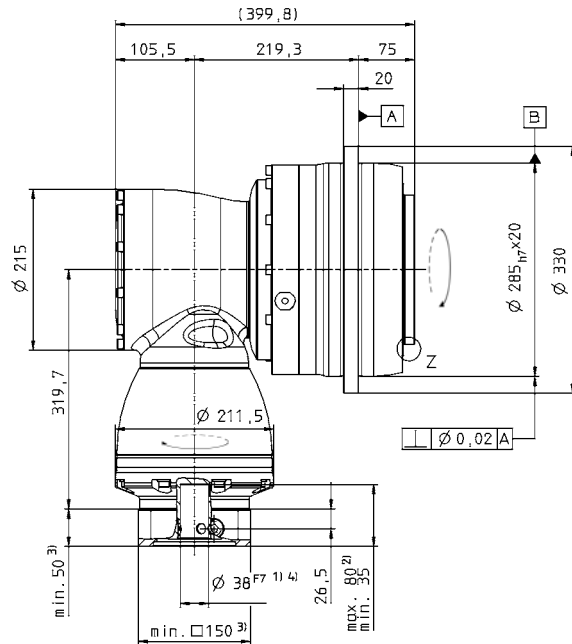
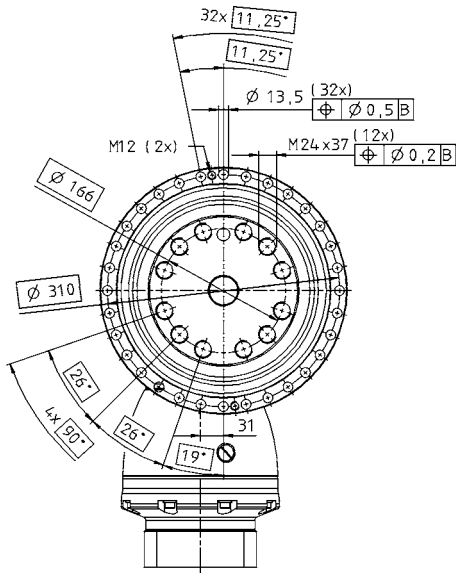

See technical data sheet for available clamping hub diameters (mass moment of inertia). Dimensions available on request.

Non-tolerated dimensions ±1 mm

- 1) Check motor shaft fit.
- 2) Min./Max. permissible motor shaft length. Longer motor shafts are adaptable, please contact us.
- 3) The dimensions depend on the motor.
- 4) Smaller motor shaft diameter is compensated by a bushing with a minimum thickness of 1 mm.

CAD data is available under www.wittenstein-alpha.com

Motor mounting according to operating manual